



UPGRADE  
ENERGY

A TOTAL SOLUTION  
FOR YOUR ENERGY NEEDS

[www.upgrade-energy.com](http://www.upgrade-energy.com)

## PREFACE

Energy prices keep rising, whereas our energy sources are becoming scarce. This not only impacts your cost structure. It also influences your competitiveness as a business. Our integrated energy models will decrease your company's dependency on the energy market and it will allow you to reduce your organisation's carbon footprint. Because companies that operate on green energy become energy producers instead of energy consumers.

And that energy is available all around us. Our energy technologies rely on renewable energy, bio energy, energy recovery and energy efficiency. Through these principals Energy Upgrade continuously develops new, custom-made solutions that enable decentralised energy generation.

Efficiently dealing with energy, finding energy saving solutions: our international experts effortlessly work on new energy projects. Continuous innovation, development of new techniques and combining them: all this generates total solutions that provide security for the future. Our 360° approach offers a complete process including research, engineering, installation and monitoring. Thanks to our financing schemes and external energy management we can even help you finance your project.

In this catalogue your will find an overview of our techniques. Energy efficiency and the transition towards renewable energy are, however, an ongoing process. That is why we keep investing in the future and we actively search for new technologies.

**Raf Vermeire, CEO Upgrade Energy**

# UPGRADE ENERGY



## DECENTRALISED ENERGY GENERATION

### YOUR INVESTMENT IN THE FUTURE

For the majority of companies, the cost of **heating, cooling and electricity** has a huge impact on the price of their end product. A cost that is often very hard to control due to the **fluctuating energy prices, rising distribution costs and taxes**. On top of this, the general energy supply is under pressure. Our dependency on obsolete nuclear plants, polluting coal plants and energy imports put us in a weak and uncontrollable position.

A focus on **energy efficiency and decentralised energy generation** not only **decreases companies' dependency** on the energy market, it

also leads to cost savings and **increases corporate social responsibility**. Investing in new energy technologies gives companies more **resilience** and more **security** for the future.

Upgrade Energy guarantees significant energy savings through the implementation of proven and innovative technologies. **Together we empower your energy!**

# UPGRADE ENERGY OFFERS A TOTAL SOLUTION FOR YOUR ENERGY NEEDS

Upgrade Energy is an engineering group with a passion to design, to install and to maintain energy projects with an integrated approach.

Through **constant innovation, strong partnerships and close monitoring of the latest technology trends** in our sector,

Upgrade Energy is able to provide your company with objective advice and the **most optimal solution** to your energy challenges.

From planning and consulting to engineering, design, construction and maintenance, Upgrade Energy covers **the entire value chain**. We even assist with the financing of your project.

## THE SIX MAIN STAGES OF AN ENERGY PROJECT

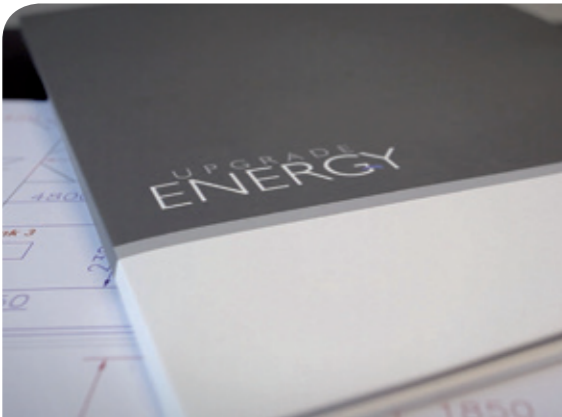

### 1 FEASIBILITY STUDY

A thorough analysis of your specific energy situation, workflow and hidden costs is the key to a successful implementation. Our team delivers in depth technical and financial feasibility analysis of your project.



### 2 PROJECT FINANCING

We are transparent about the required investment to realise your energy project. We understand the need for companies to focus and allocate capital to their core activities. That is why we offer **financing schemes**, to offer companies the opportunity to benefit from cheap renewable electricity without the heavy burden of the investment.



### 3 ENGINEERING

Upgrade Energy takes care of every aspect in the engineering phase and offers detailed design of your project.



### 4 PROJECT EXECUTION

An experienced team of engineers, project managers and technicians ensures a professional follow-up. Our project managers are frequently present on site and you are assigned one dedicated contact person.



### 5 MONITORING

When your installation is fully operational, a monitoring system will allow you to check the performance of your installation at all times. This way of working also enables us to continually evaluate your energy profile. Thanks to close monitoring, you can save up to 30 % in energy, and keep improving.



### 6 MAINTENANCE

In order to detect possible defects, we offer (optional) maintenance contracts for every project. This means periodic inspection, expert maintenance and rapid repair if necessary, limiting the down time of your installation and maintaining optimal efficiency throughout its lifespan.

# SAVE ENERGY THROUGH THE IMPLEMENTATION OF PROVEN AND INNOVATIVE TECHNOLOGIES

When asked which energy source secures the future, our answer is clear but not easy. **The supply of fossil fuels is limited**, new energy technologies are the answer to the energy problem. However, no single technology can meet our society's future energy needs. **Research, development and a smart combination of multiple technologies are essential in providing a sustainable solution.**

Upgrade Energy is experienced in a large number of renewable energy technologies which allows an **objective assessment** and the implementation of **the right energy solution** or combination of various measures.

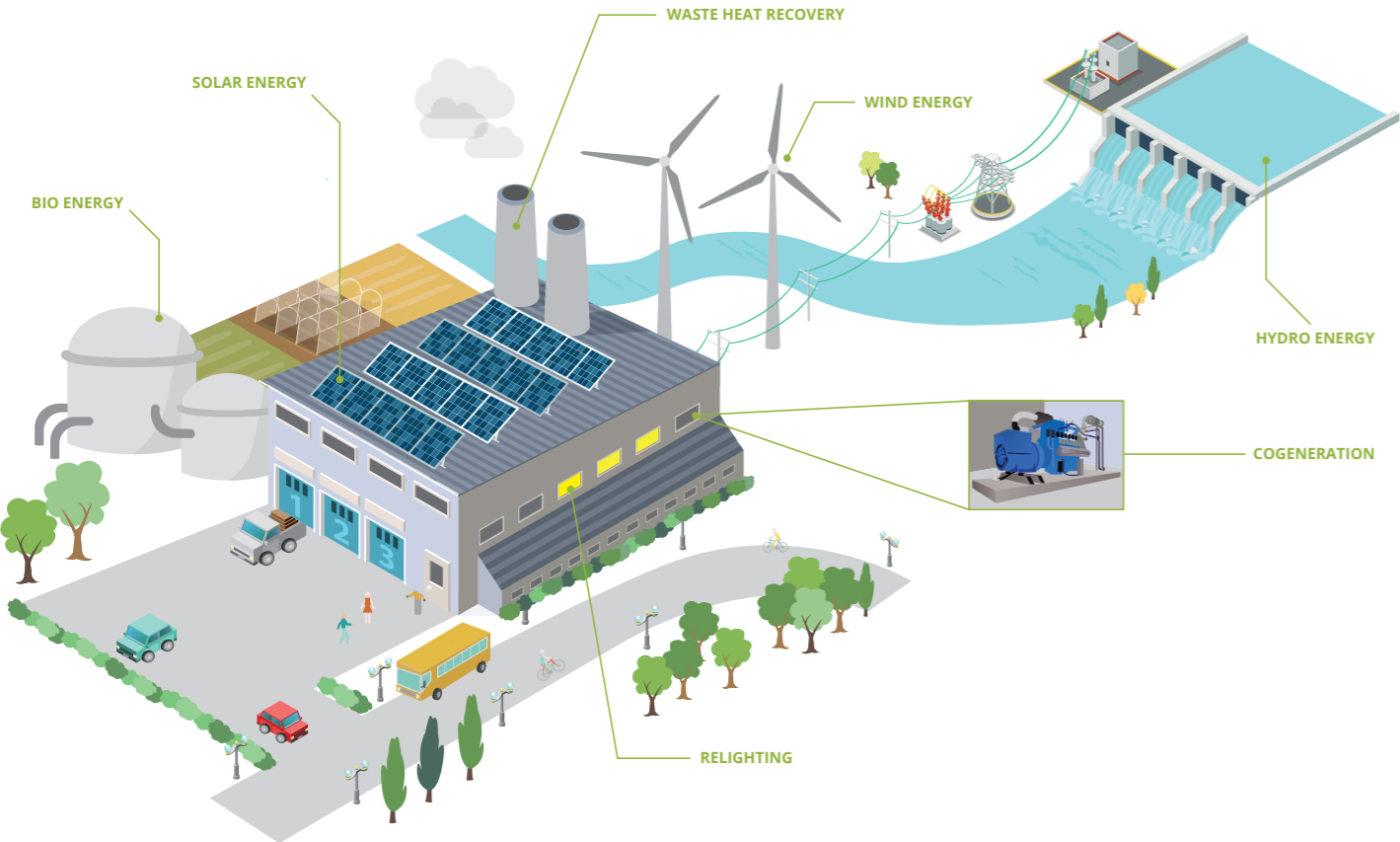

**Relighting (LED)**

Replace your lighting and reduce your electricity consumption by 50 to 80%.

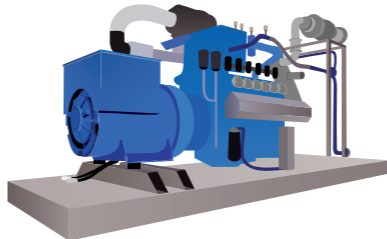

**Cogeneration and trigeneration**

Make use of the most efficient technology to generate heat and electricity simultaneously.

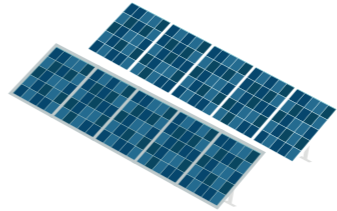

**Solar energy**

Instantly save on your energy bills with the sun's free energy.

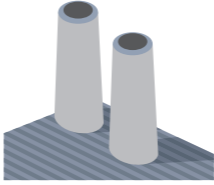

**Waste heat recovery**

Profit from the industrial waste heat from your production processes and transform it into electricity or cooling



**Wind energy**

For large business sites, your ultimate green energy source.

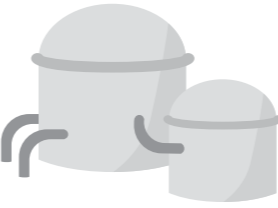

**Bio energy**

Extract energy from organic waste, available at the company's site.

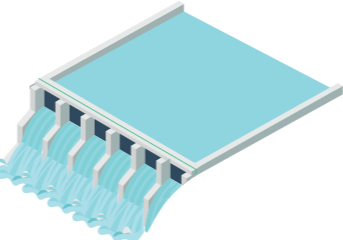

**Hydro energy**

Make use of this abundant form of clean energy. It's free, unlimited and flexible.



## EXTERNAL ENERGY MANAGEMENT

### WE HELP YOU FINANCE YOUR PROJECT

The cost of energy continues to rise. That has a direct **impact on the competitiveness** of our businesses. Many large companies and public authorities have therefore already made the move towards greater energy efficiency. SMEs have also put energy saving on the agenda. But for them, the **implementation of energy saving measures can be a complex process**. Getting the financing

up to speed requires a lot of effort and expertise. Upgrade Energy is **specialised in financing models tailored to your needs and possibilities**, offering you immediate results due to energy savings. Whether a project is financed through third party financing or not, Upgrade Energy is the perfect partner and we can **assist you legally and financially**.

**Energy efficiency is a pending issue in many organisations.** We find that many companies postpone energy saving measures because they want to retain the capital for their core business. And rightly so. That's why more and more companies opt for an external energy manager. **External energy management** is a possible solution to implement the desired measures without having to invest.

**External energy management is a possible solution to implement the desired measures without having to invest.**

**defining saving measures** After a thorough energy scan the measures that will achieve significant energy savings for your company are listed and described. This study also provides detailed advice on the technical feasibility and financial viability of the possible measures.

**financing** **implementation** Upgrade Energy finances and implements saving measure.

**Energy user** **Energy manager** Upgrade Energy makes the installation available for a fixed annual fee

annual fee

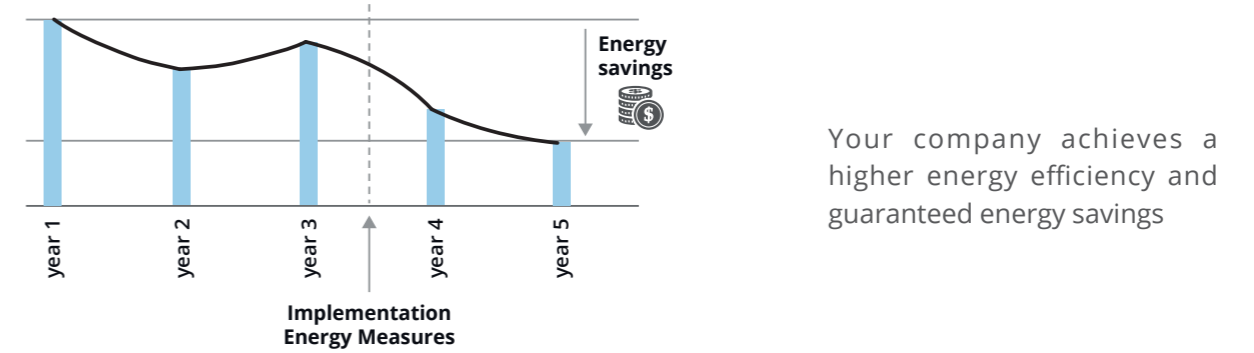

**extra measure** This process can be gone through for every efficiency measure at the company's site.

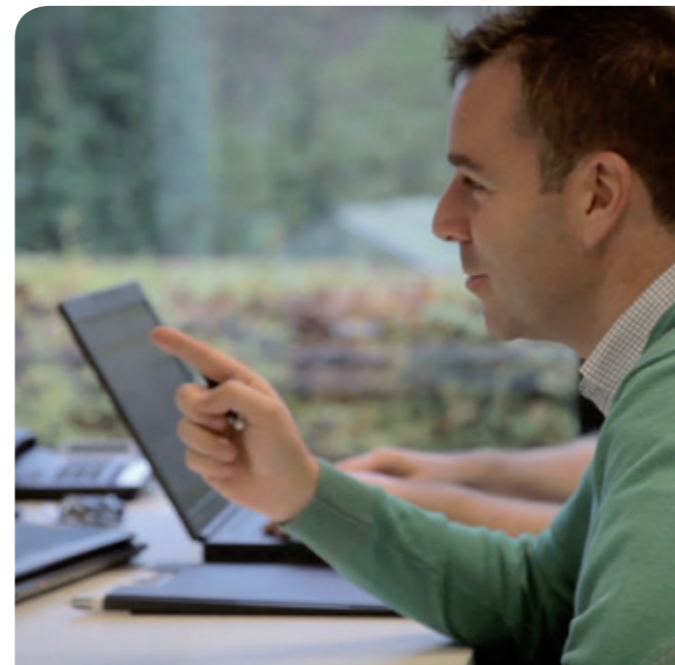

## INTERNATIONAL PROJECT COORDINATION

Upgrade Energy's headquarters are in Belgium and has six regional offices in Europe, Africa and Asia. We are experienced in international project coordination and realise projects all over the world.



## TOGETHER, WE MAKE IT HAPPEN

A changing climate, a limited supply of fossil fuels, ever increasing energy prices... It is clear we need to come up with more green and efficient energy technology. As an energy consultant, Upgrade Energy is at the centre of this transition.

- ✓ We **analyse your specific needs** and offer **advice tailored to your company**, to help you make the transformation from an **energy consuming** to an **energy producing company**.
- ✓ We are there every step of the way: from **planning** and **consulting** to **engineering, design, construction, maintenance** and **asset management**. Upgrade Energy covers the **entire value chain**.
- ✓ Even for the **financing** of your project you can count on Upgrade Energy.

Upgrade Energy is your **one stop shop** for a better today and a greener tomorrow, for you and your company. Our consultants are happy to visit your company, have a look at the possibilities and provide you with a **possible roadmap**.

Contact one of our offices for more info!

# OVERVIEW OF UPGRADE ENERGY'S TECHNOLOGY PORTFOLIO



# INDUSTRY ... HELPING COMPANIES SAVE ENERGY

Waste heat recovery ..... 10

- 1. ORC
- 2. cooling



Decentralized energy production ..... 10

- 1. Cogeneration
- 2. Trigeneration
- 3. Steam turbines
- 4. Gas turbines



Energy storage ..... 10

- 1. Batteries
- 2. Cold storage
- 3. Heat storage



# RENEWABLES DEVELOPMENT ... FOR GRID INJECTION

## Renewables coverage ..... 10

- 1. Solar energy (heat & electricity)
- 2. Wind energy



## Energy efficiency ..... 10

- 1. Industrial heat pump
- 2. LED lighting



## Solar parks (with grid stabilization)..... 10



## Wind turbines..... 12



## Hydro-electric power plants ..... 14



## Waste-to-energy plants..... 14



# BIOMASS ...CO<sup>2</sup> NEUTRAL POWER PRODUCTION

Gassification (pyrolysis) ..... 10



Anaerobic digestion ..... 12



Biomass combustion ..... 14



ORGANIC  
RANKINE CYCLE  
ELECTRICITY FROM WASTE HEAT



ORGANIC RANKINE CYCLE

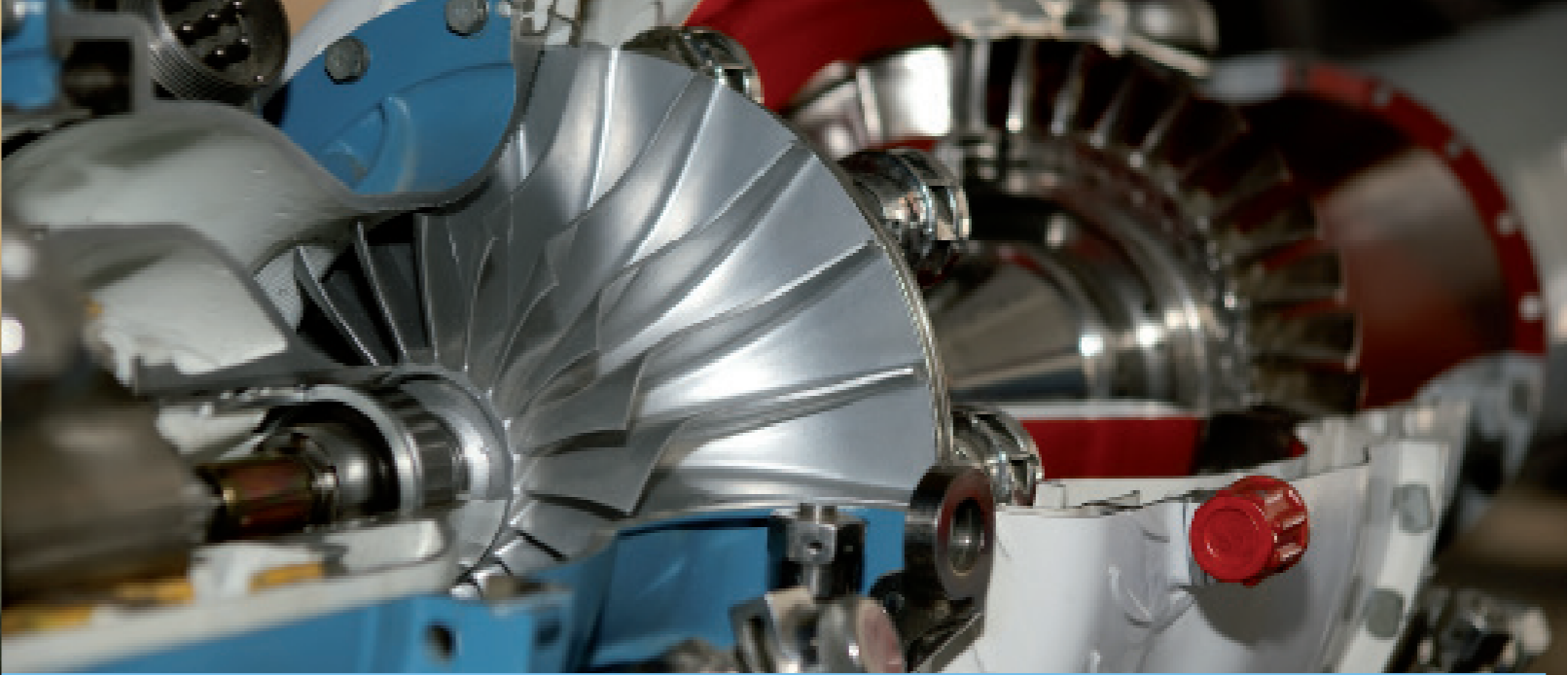

## WASTE HEAT



## ELECTRICITY

### WHAT IS ORC?

An Organic Rankine Cycle is an installation that converts thermal energy, in the form of waste heat, into electricity.

ORC technology is based on the known and proven Rankine Cycle principle

### WORKING PRINCIPLE

During the Rankine Cycle, heat is converted into work through the expansion of vapor. This vapor drives a turbine, which drives an electric generator.

Instead of using water (like in a steam turbine), an ORC system vaporizes an organic liquid. This organic liquid has a high molecular weight and a boiling point lower than that of water (e.g. toluene, freon). Because it evaporates at lower temperatures than water, ORC systems can generate electricity from waste heat at lower temperatures than steam turbines.

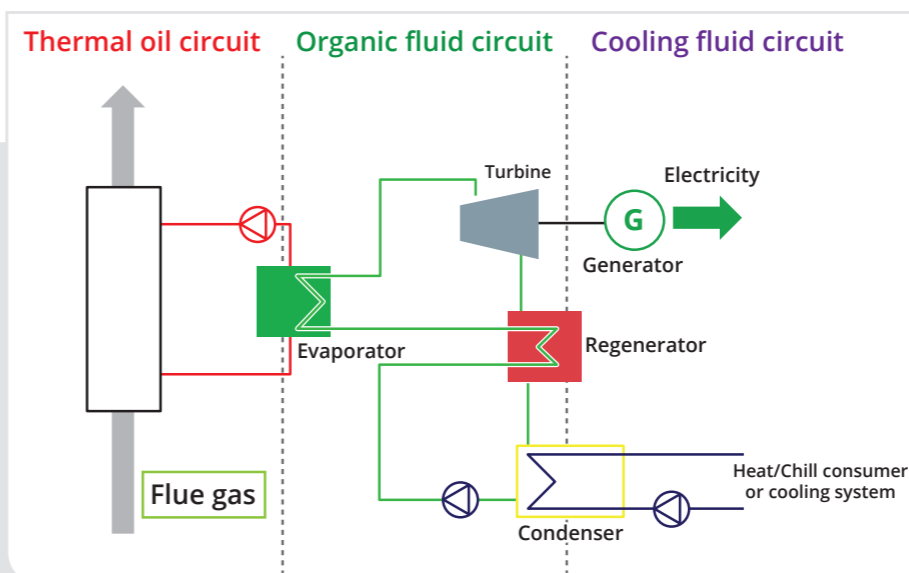

### PROCESS DESCRIPTION

- A pre-feed pump brings the organic working fluid from the vessel to the main pump and increases the pressure to about 4 bar.
- The main pump (behind the condenser) brings the liquid to the required pressure (about 30 bar), depending on the desired rotation speed of the turbine.
- The liquid is preheated in the regenerator by the vapor that leaves the turbine, in the evaporator it is heated further, evaporated and overheated.
- Then the liquid expands in the turbine. This enables the turbines to drive the main pump and the electricity generator.
- In the regenerator and then the condenser, the liquid condenses by air or water cooling. The liquid returns to the main pump and the cycle resumes.

### BENEFITS

- ✓ Primary energy savings
- ✓ Reduction of CO<sub>2</sub> emissions
- ✓ Long life span: about 20 years
- ✓ Low maintenance
- ✓ Broad operating range (10-100%)
- ✓ Good efficiencies at part load
- ✓ Lower temperatures and pressures compared to steam turbines
- ✓ Modular design
- ✓ Quiet operation



## APPLICATIONS OF ORC

ORC can be used in all processes that have waste heat.

- Industries:
  - Metal
  - Construction materials
  - Food
  - Molding
- Biomass combustion
- Marine
- Geothermal
- Solar collectorheat



## CASE STUDY

A brick manufacturer has 900kWth residual heat from the brick oven available for 8500h/year. Our ORC module can generate 125 kW of electricity from this waste heat.



ORC 125 KWE	COST/RETURNS PER YEAR
Maintenance	€ -20.250,00
ORC cooling consumption	€ -7.905,00
Returns electricity*	€ 127.500,00
<b>Total savings</b>	<b>€ 99.345,00</b>
Investment	€ 485.760,00
<b>Payback period</b>	<b>4,9 year</b>

\*At an electricity price of 120 EUR/MWh



## REFERENCE CASE

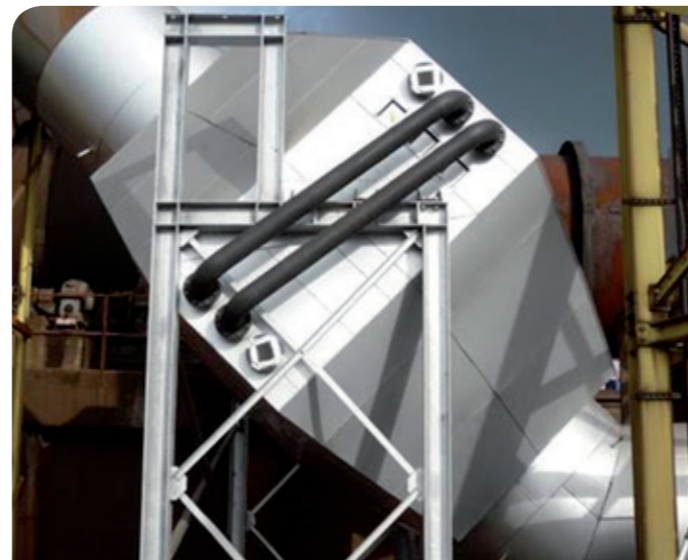

Client	Argex
Industry type	Construction materials
Heat source	3 MWth from flue gas @ 200-250°C
Capacity	3 ORC units x 125 kWe = 375 kWe
Commissioning	2013

## CONCLUSION

As part of a sustainable and environmental policy, ORC technology turns waste heat into useful renewable energy.

With ORC technology, your business contributes to a greener future, in an economically viable way.





# ABSORPTION COOLING

USING WASTE HEAT FOR COOLING



# ABSORPTION COOLING

## WHAT IS ABSORPTION COOLING?

Absorption cooling uses thermal energy instead of electricity to generate cooling.

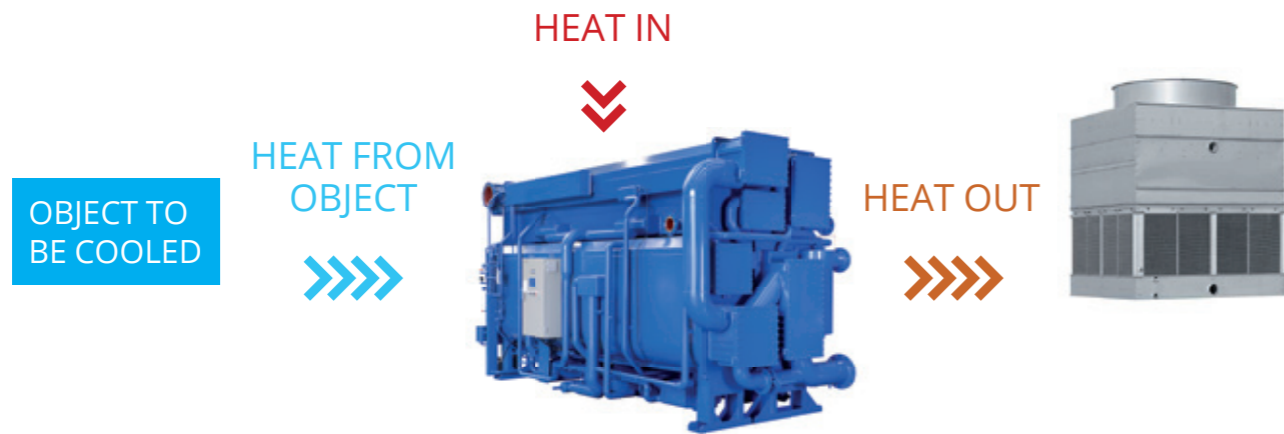

Like your refrigerator at home, cooling is generated by the transportation of heat from the object to be cooled to the cooling circuit. This extraction of warmth is caused by the expansion of the refrigerant in the cooling circuit. For this expansion, a refrigerant under pressure is needed. Therefore, it must first be compressed. Instead of using an electrical compressor (like in your refrigerator), the absorption cooling technology uses a "thermal compressor" in order to bring the refrigerant at a higher pressure. It is this heat that drives the installation instead of electricity. This allows significant electricity savings, compared to traditional cooling. Only the feeding pump uses a limited amount of electricity.

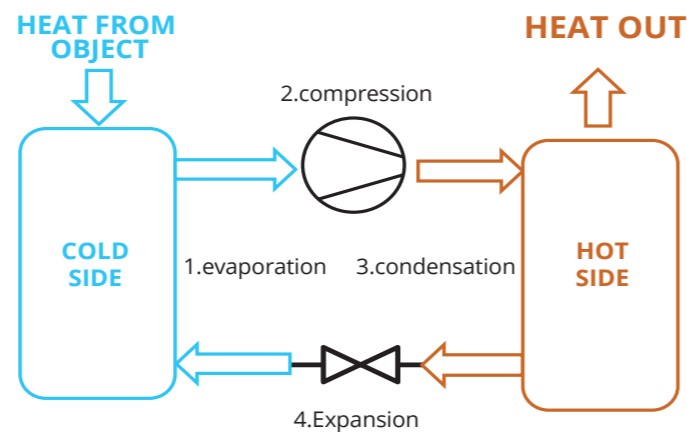

## WORKING PRINCIPLE

### The traditional cooling cycle with electrical compression

The refrigerant extracts heat from the environment to be cooled through **evaporation** (in the evaporator). The evaporated refrigerant is then compressed to a higher pressure by an electrically driven **compressor**, liquefying it. The liquefied refrigerant is then condensed in the **condenser**, decreasing the temperature while remaining at the same pressure level. Once the refrigerant is cooled, it is expanded over an **expansion valve**. Finally, the low temperature refrigerant returns to the evaporator where the pressure is lower, evaporates and starts to extract heat from the environment again.

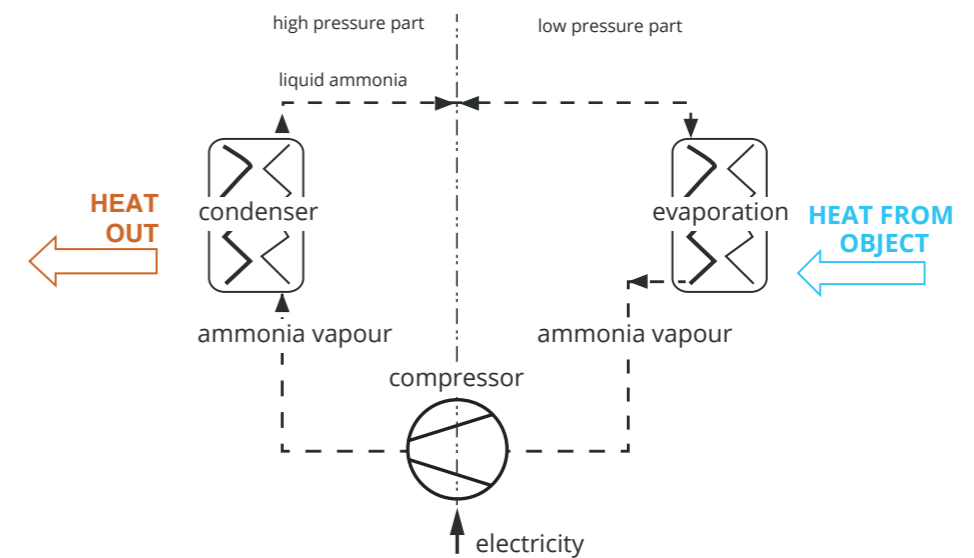



## The absorption cooling cycle with “thermal compression”

In an absorption cooling installation, the thermal compression phase is enabled through a solution circuit. A liquid absorbing agent dissolves the refrigerant vapor in the **absorber**. The absorbent liquid, enriched with refrigerant, is pumped to a higher pressure level in the **rectification column**. At this stage, the refrigerant is separated from the liquid solution by supplying heat. An external heat source heats the solution to the boiling point of the refrigerant, leading to the evaporation of the refrigerant. The liquid solution, now with much less refrigerant, returns to the absorber. The refrigerant vapor is sent to the condenser, where it liquifies.

The cooled refrigerant returns to the evaporator to extract heat from the environment. The cycle can resume.

The process heat needs to be removed through air or water cooling at ambient temperatures.

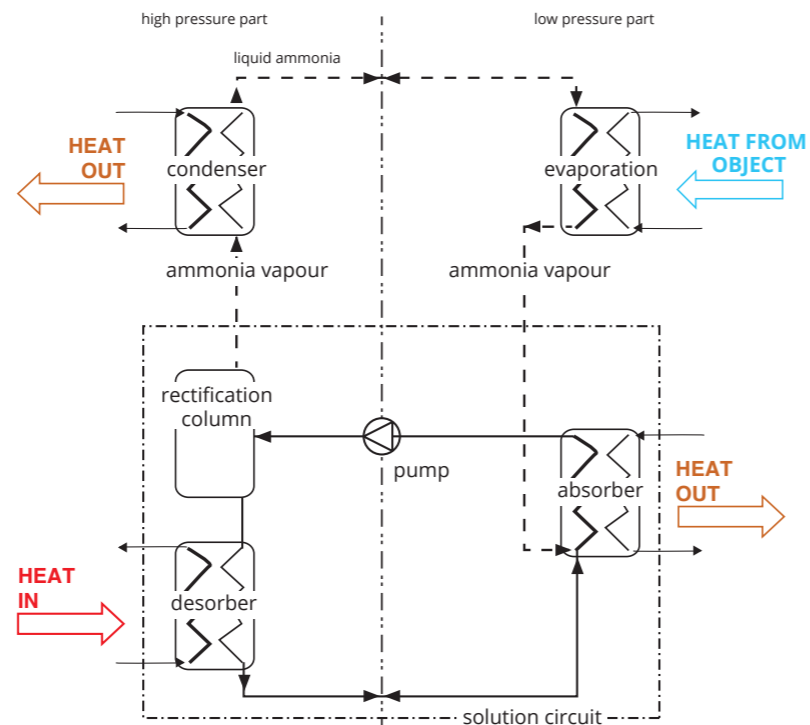

## EFFICIENCY

Depending on the operating temperatures of both the cold and the hot side, the COP value of the installation will be between 0,5 and 1,3.

- The hotter the heat source, the higher the COP.
- The colder the ambient temperatures, the easier the cooling, the higher the COP.

## BENEFITS

- ✓ Less electricity consumption
- ✓ Decrease in primary energy consumption and CO<sub>2</sub> emissions
- ✓ Free source of energy: waste heat
- ✓ Low maintenance costs
- ✓ Existing cooling can remain as back-up
- ✓ Long life span: 20 years



## APPLICATIONS

### Industries:

- Food (cold storage, slaughter houses, ...)
- Extrusion
- Synthetics
- Cold storage of fruit, vegetables, meat, dairy, pastoy,...
- Data centers
- Air cooling
- Pulp mills
- Printing

### Possible heat sources:

- Residual process heat
- Heat from exhaust gasses
- Hot water
- Geothermal heat
- Heat from solar collectors
- Heat from biomass boilers/waste incineation
- District heating

As long as the temperature is higher than 80°C.

Upgrade Energy installs absorption chillers form 100 kW to 5000 kW cooling capacity. Our absorption chillers cool down to 5°C, and in special cases down to -60°C.

## REFERENCE



Client	Belgian Fibers Manufacturing
Industry type	Fibers
Hot source	waste heat from CHP engine
Capacity	409 kW cooling
Commissioning	2016

## CONCLUSION

Absorption cooling covers your cooling needs, while saving on electricity consumption.

It saves primary energy by using waste heat as energy source and decreases your company's CO<sub>2</sub> emission. With absorption cooling, your business contributes to a greener future, in an economically viable way.





# COMBINED HEAT AND POWER (CHP)

MORE EFFICIENT HEAT AND POWER



## COMBINED HEAT AND POWER

### WHAT IS CHP?

A combined heat and power (CHP) installation is a power plant that produces heat and electricity by burning fuel.



### PURPOSE

The purpose of a CHP installation is to save primary energy. Heat and electricity are generated simultaneously at the same location, through the combustion of fuel. The efficiency of this energy generation is much higher than buying electricity from the grid and generating heat separately. Transport and distribution losses are avoided and waste heat from electricity generation is applied in a useful way. With a classic electricity production the produced heat is blown off into the atmosphere.

CHP technology reduces primary energy consumption up to 50%.

Moreover, 1 kWh of gas is cheaper than 1 kWh electricity, which makes CHP technology reduce your overall energy costs.

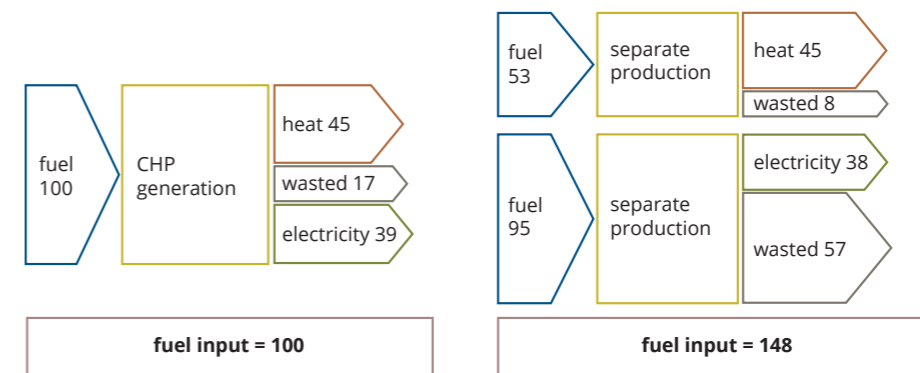

### ELECTRICITY



### FUEL



Upgrade Energy's CHP units consist of a gas engine coupled to a generator. The motor runs on natural gas, biogas, syngas or other fuels and drives the generator, which produces electricity.

The heat from the engine's motor bloc and from the fuel mixture cooling is utilized in the local process (e.g. water heating, drying + thermal oil heating).

### HEAT

### BENEFITS

- ✓ Big savings on electricity costs by own generation
- ✓ More independence from the volatile energy market
- ✓ Optimal usage of fuel
- ✓ Saving primary energy, reducing the CO<sub>2</sub> impact.
- ✓ Existing systems can remain as back-up
- ✓ Long lifespan: 60 000 operating hours, when subjected to big revision, 120 000 operating hours.



## APPLICATIONS

### INDUSTRIES

- Food
- Pharmaceutical
- Chemical
- Extrusion
- Logistics
- Greenhouses
- Residential (hotels, apartment buildings, district heating systems)

- Processes with a continuous heat and electricity consumption of 5000 hours or more per year.
- Production units with a high electricity price and a low fuel price

For example:

Running hours per year	8000
Fuel price [€/MWh]	25
Electricity price [€/MWh]	95
Ratio electr./fuel price	3,80
Capacity [kW]	1000
Payback period [years]	3,2
Investment [million €]	1

Upgrade Energy installs and maintains CHP installations from 100 kW to 8 MW.



CLASSIC SITUATION



CHP SITUATION

## CASE STUDY

A classic heating system with electricity purchase from the grid is compared to a CHP installation, with the same energy performances.

### CLASSIC SITUATION

The table below summarizes what is consumed to buy 1498 kWe from the grid and to generate 1714 kW heat by combustion of natural gas, with a thermal efficiency of 90%.

CLASSIC SITUATION	CAPACITY		ENERGY		FINANCIAL	
Electricity consumption from the grid	-1.498	kWe	-12.284	MWh e/y	-1.424.898	€/year
Natural gas consumption	-1.714	kWth	-15.616	MWh gas/y	-437.260	€/year
Maintenance installation					-	€/year
<b>Total energy cost</b>					<b>-1.862.158</b>	<b>€/year</b>

### CHP SITUATION

This table summarizes the consumption and costs of a CHP unit that produces the same amount of heat and electricity.

CHP SITUATION	CAPACITY		ENERGY		FINANCIAL	
Natural gas consumption CHP	-3.752	kWgas	-30.769	MWh gas/y	-861.533	€/year
Heat production CHP	1.714	kWth	15.616	MWh gas/y	437.260	€/year
Electricity production CHP	1.560	kWe	12.792	MWh e/y	1.483.872	€/year
Parasitic losses CHP (pumps, valves, coolers,...)	-62,4	kWe	-512	MWh e/y	-59.355	€/year
Net electricity production CHP	1.498	kWe	12.280	MWh e/y	1.424.517	€/year
Maintenance CHP installation					-113.570	€/year
<b>Total cost of energy consumption</b>					<b>-886.675</b>	<b>€/year</b>

### DIFFERENCE

Using the CHP installation for the same energy performance will generate 975.483 € savings every year.

## SUMMARY

TOTAL SAVINGS CHP		
Energy savings due to CHP	975.483	€/year
Governmental support green energy	343.000	€/year
Net savings compared to classic installation	1.318.483	€/year
Investment	3.968.245	€
Payback period	3	years

These figures were calculated based on 8200 operational hours per year. An electricity price of € 116 / MWh and a gas price of € 28 / MWh were taken into account.

## REFERENCES



Client	Capsugel (Belgium)
Industry type	Pharmaceutical
Capacity	1200 kWel + 1258 kWth
Fuel	Natural gas
Commissioning	2014



Client	Gramybel (Belgium)
Industry type	Potato industry
Capacity	889 kWel + 918 kWth
Fuel	Natural gas and biogas
Commissioning	2015



## CONCLUSION

### A CHP INSTALLATION

- Produces heat
- Produces electricity
- It reduces energy costs

1. By own (cheaper) generation of electricity
  2. By using the free excess heat resulting from the CHP installation, instead of buying fuel
- For every kWh of fuel the CHP consumes, it provides more valuable electricity and useful heat.

As part of a sustainable and environmentally friendly policy, the CHP technology saves primary energy and decreases your company's CO<sub>2</sub> emissions.





# TRIGENERATION

SUSTAINABLE ELECTRICITY, HEAT AND COOLING



## WHAT IS TRIGENERATION?

Trigeneration is the simultaneous generation of heat, cooling and power, using natural gas or biogas as a fuel. Trigeneration technology consists of combined heat and power (CHP) technology + absorption cooling.

Local and simultaneous generation of heat, cooling and power is more economical, than buying these energy sources separately from different sources. With trigeneration, transmission losses of the electricity grid are avoided and excess heat (coming from electricity production) is applied usefully, in the form of process heat or cooling.

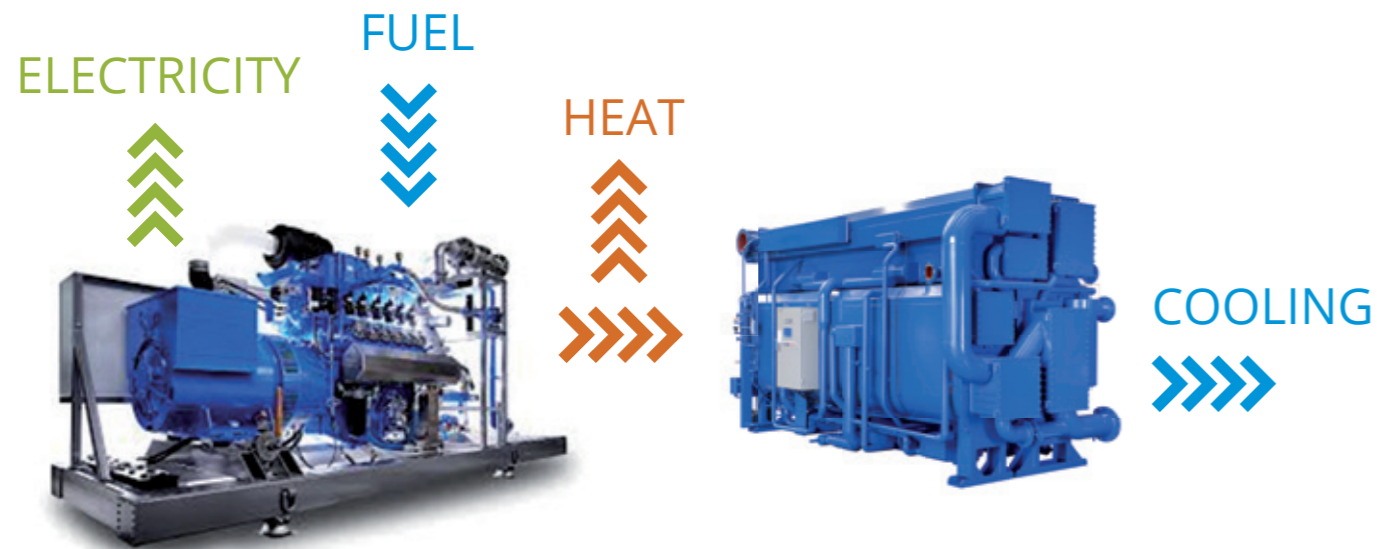

## COMBINED HEAT AND POWER

### WHAT IS IT?

A combined heat and power (CHP) installation is a power plant that produces heat and electricity by burning fuel.

Our CHP units consist of a gas engine, coupled to an electric generator. The motor runs on natural gas and drives the generator, which produces electricity. The heat released by the engine is utilized in the local process (e.g. water heating, drying process, thermal oil heating, etc.).

### PURPOSE

The purpose of a CHP installation is to save primary energy. Heat and electricity are generated simultaneously and on the same location, through the combustion of fuel. The efficiency of this energy generation is much higher than buying electricity from the grid and generating heat separately. Transport and distribution losses are avoided and waste heat from electricity generation is applied in a useful way. With a classic electricity production system the produced heat is blown off into the atmosphere.

CHP technology reduces primary energy consumption up to 50%.

Moreover, 1 kWh of gas is cheaper than 1 kWh electricity, which makes CHP technology reduce your overall energy costs.

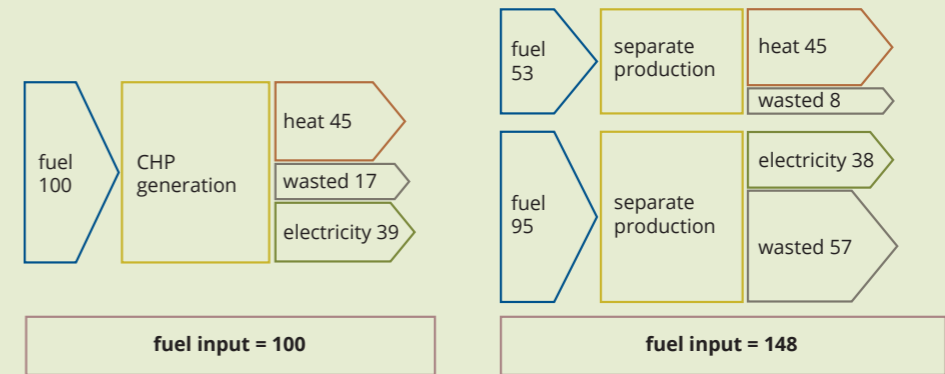

### BENEFITS OF CHP

- ✓ Big savings on electricity costs by own generation
- ✓ More independence from the volatile energy market
- ✓ Optimal usage of fuel
- ✓ Saving primary energy, reducing CO<sub>2</sub> impact.
- ✓ Existing systems can remain as back-up
- ✓ Long lifespan: 60 000 operating hours, when subjected to big revision, 120 000 operating hours.



# ABSORPTION COOLING

## WHAT IS IT?

Absorption cooling uses thermal energy instead of electricity to generate cooling.

Like your refrigerator at home, cooling is generated by the transportation of heat from the object to be cooled, to the cooling circuit. This extraction of warmth is caused by the expansion of the refrigerant in the cooling circuit. For this expansion, a refrigerant under pressure is needed. Therefore, it must first be compressed. Instead of using an electrical compressor (like in your refrigerator), absorption cooling technology uses a "thermal compressor" in order to bring the refrigerant at a higher pressure. It is this heat that drives the installation instead of electricity. This allows significant electricity savings compared to traditional cooling. Only the feeding pump uses a limited amount of electricity.

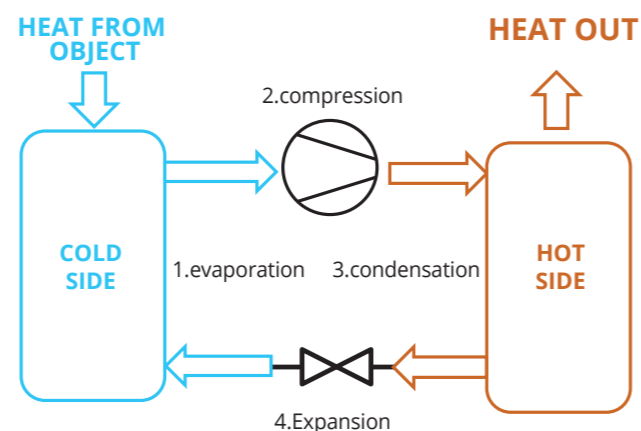

## WORKING PRINCIPLE

### 1. The traditional cooling cycle with electrical compression

The refrigerant extracts heat from the environment to be cooled through **evaporation** (in the evaporator). The evaporated refrigerant is then compressed to a higher pressure by an electrically driven **compressor**, liquefying it. The liquefied refrigerant is then condensed in the **condenser**, decreasing the temperature while remaining at the same pressure level. After the refrigerant is cooled, it is expanded over an **expansion valve**. Finally, the low temperature refrigerant returns to the evaporator where the pressure is lower, evaporates and ready to extract heat from the environment again.

### 2. The absorption cooling cycle with "thermal compression"

In an absorption cooling installation, the thermal compression phase is enabled through a solution circuit. A liquid absorbing agent dissolves the refrigerant vapor in the **absorber**. The absorbent liquid, enriched with refrigerant, is pumped to a higher pressure level in the **rectification column**. Here, the refrigerant is separated from the liquid solution, by supplying heat. An external heat source heats the solution to the boiling point of the refrigerant, leading to the evaporation of the refrigerant. The liquid solution, now with much less refrigerant, returns to the absorber. The refrigerant vapor is sent to the condenser, where it liquifies. The cooled refrigerant returns to the evaporator to extract heat from the environment. The cycle can resume. The process heat needs to be removed through air or water cooling, at ambient temperatures.

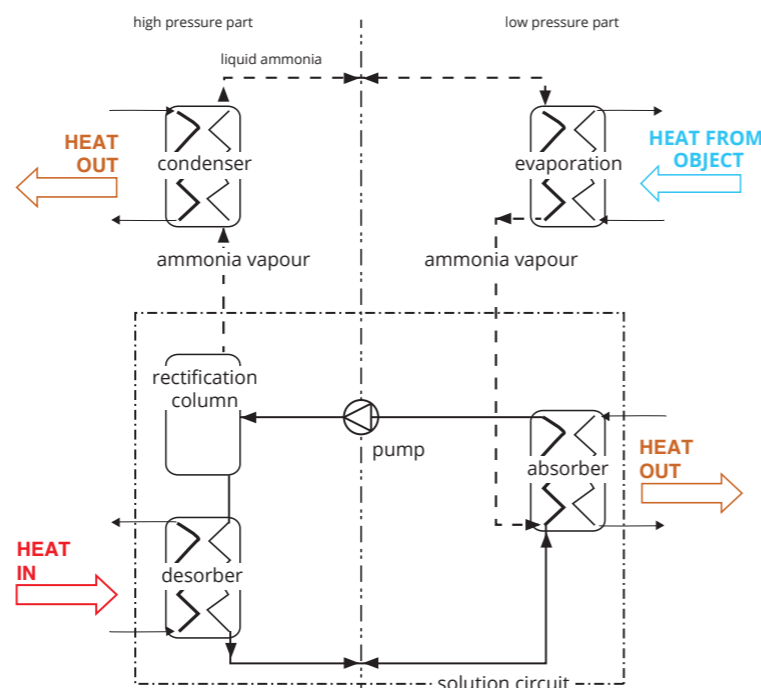

## EFFICIENCY

Depending on the operating temperatures of both the cold and the hot side, the COP value of the installation will be between 0,5 and 1,3.

- The hotter the heat source, the higher the COP.
- The colder the ambient temperatures, the easier the cooling, the higher the COP.

## BENEFITS OF ABSORPTION COOLING

- ✓ Less electricity consumption
- ✓ Less primary energy consumption and lower CO<sub>2</sub> emissions
- ✓ Free source of energy: waste heat
- ✓ Low maintenance costs
- ✓ Existing cooling system can remain as back-up
- ✓ Long life span: 20 years

# APPLICATIONS

## INDUSTRIES

- Fibers
- Food
- Metal
- Logistics
- Extrusion
- Residential (hot summers)
- Breweries



- Processes with a continuous cooling (and heat) and electricity consumption of 5000 hours per year.
- Production units with a high electricity price and a low fuel price
- Production units with an electrical baseload of at least 350 kW

For example:

Running hours per year	8000	hours
Fuel price	25	€/MWh
Electricity price	95	€/MWh
Ratio electr./fuel price	3,80	€
Capacity	1000	kW
Payback period	2,7	years
Investment	1,6	million €

In this case 50% of the heat is used for cooling a process cooling circuit from 25°C to 15°C. Our absorption chillers cool down to 5°C, in special cases down to -60°C.

## CASE STUDY

A classic heating system with electricity purchase from the grid is compared to a CHP installation, with the same energy performances.

- 1151 kW cooling at 5°C – 20°C
- 462 kW cooling under 5°C

### CLASSIC SITUATION

The table below summarizes what is consumed to buy 1498 kWe from the grid and to generate 1714 kW heat by combustion of natural gas, with a thermal efficiency of 90%.

Classic situation	Capacity	Energy	Financial
Electricity consumption for cooling 5 -20°C	-384 kWe	-3.147 MWhe/year	-365.033 €/year
Electricity consumption for cooling < 5°C	-154 kWe	-1.262 MWhe/year	-146.390 €/year
Net electricity consumption	-538 kWe	-4.409 MWhe/year	-511.422 €/year
Maintenance installation			-9.465 €/year
<b>Total energy cost</b>			<b>-520.887 €/year</b>

### SITUATION WITH TRIGENERATION

This second table summarizes the consumption and savings of a CHP unit which produces the same amount of heat and electricity.

With Trigeneration	Capacity	Energy	Financial
Gas consumption	-1.054 kWgas	-8.644 MWh gas/y	-242.044 €/year
Available heat for coolingC	462 kWgas	3.786 MWh gas/y	
Electricity savings absorption chiller	154 kWe	1.262 MWhe/year	146.390 €/year
Electricity production	400 kWe	3.278 MWhe/year	380.242 €/year
Parasitic losses	-16,0 kWe	-131 MWhe/year	-15.210 €/year
Net electricity generation for cooling < 5°C	384 kWe	3147 MWhe/year	365.033 €/year
Operation and maintenance costs installation			-61.537 €/year
<b>Total energy cost</b>			<b>-303.581 €/year</b>

These figures are calculated based on 8200 running hours per year and a COP value = 3, for the classic situation. An electricity price of 116 €/MWh and a gas price of 28 €/MWh are taken into account.

### DIFFERENCE

The trigeneration installation costs 217 306 EUR/year less, for the same performances.

### SUMMARY

Net energy savings	217.306	€/year
Investment	804.654	€
Payback period	3,7	year

## REFERENCE



Client	Belgian Fibers Manufacturing
Industry type	Fiber production
Cooling	Fiber cooling
Capacity	409 kW cooling 1000 kW electricity 513 kW heat
Commissioning	2016

## CONCLUSION

A trigeneration installation produces

- Electricity
- Heat (if required)
- Cooling

And reduces energy costs

1. By generating own electricity
2. By using less electricity for cooling
3. By applying excess heat usefully

For every kWh of fuel the CHP consumes, it provides more valuable electricity and useful heat.

As part of a sustainable and environmentally friendly policy, the trigeneration technology saves primary energy and decreases your company's CO2 emissions.



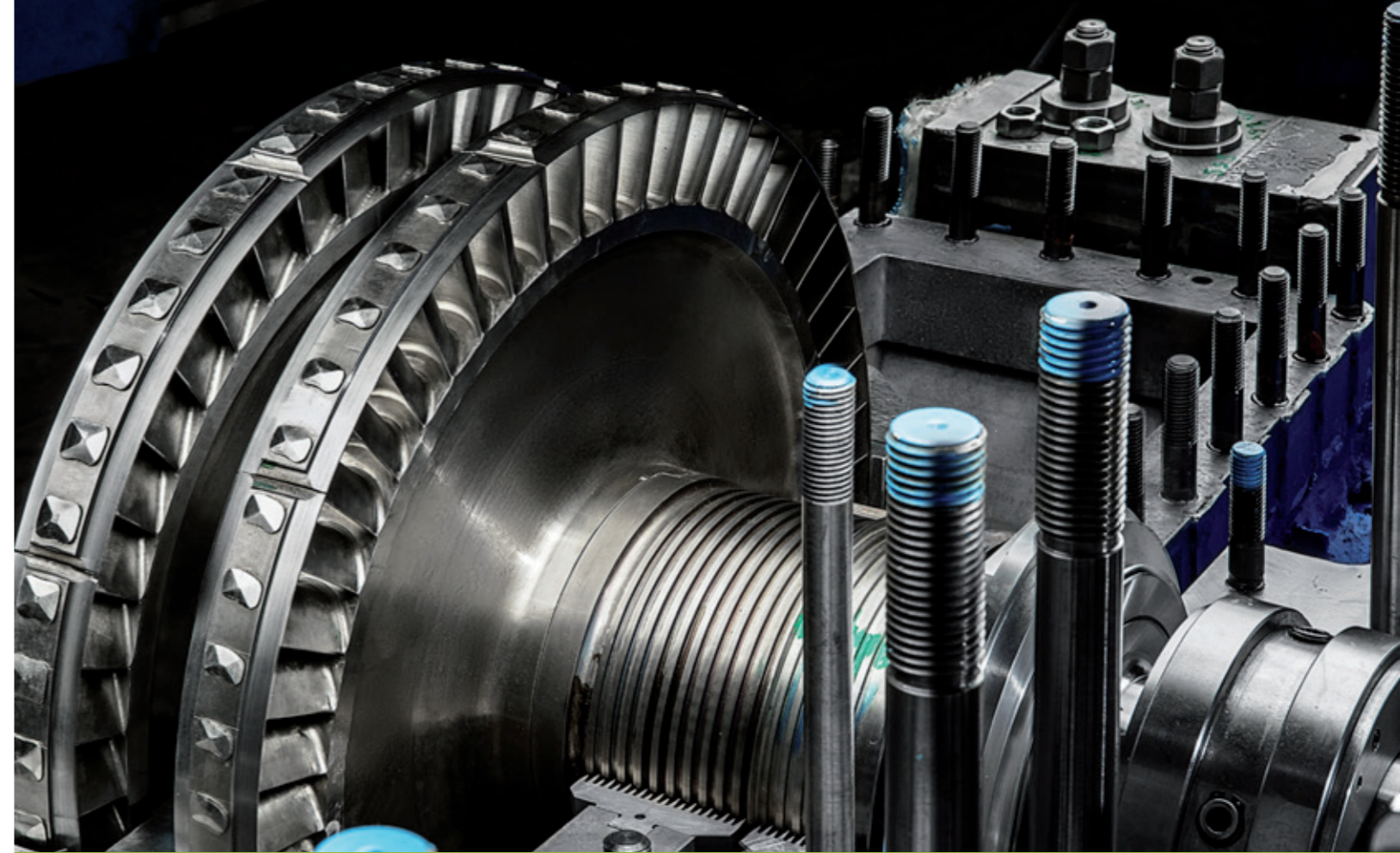

# STEAM TURBINE

ON-SITE ELECTRICITY GENERATION



## STEAM TURBINE

### WHAT IS IT?

A steam turbine converts thermal energy, in the form of steam, into electricity.

The principle of steam generation is based on the well-known thermodynamic Rankine cycle.

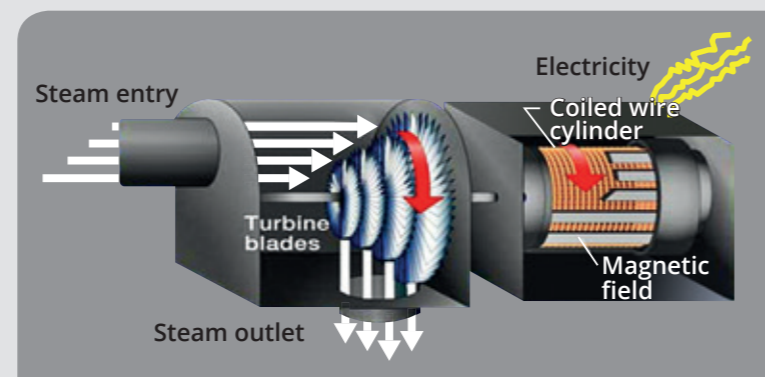

### WORKING PRINCIPLE

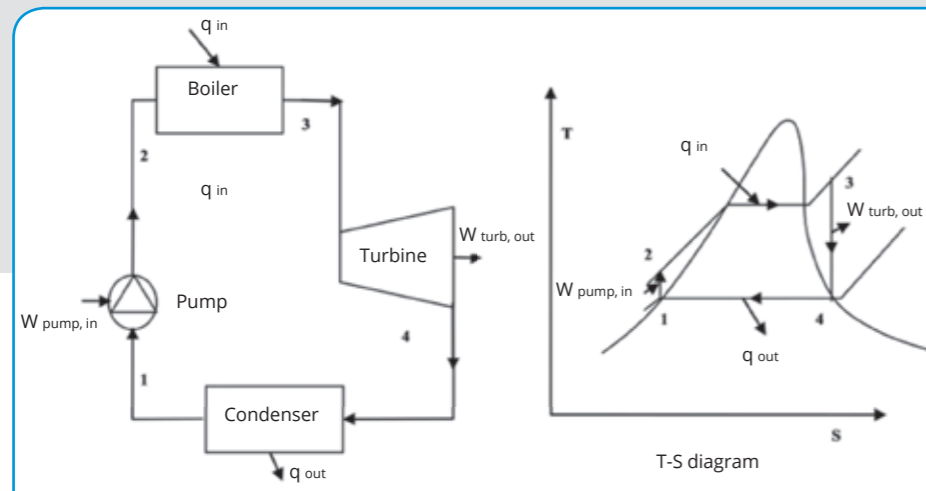

Superheated steam is produced, in a boiler or by a residual heat source. The heat transforms water into steam under high pressure. Through a pressure resistant pipe, the steam is brought to the steam turbine where it is expanded. The turbine is set in motion by the expansion, and drives a generator. The generator produces electricity. The main advantage of the steam turbine is that fuel or (unused) waste heat can be applied efficiently for the generation of expensive electricity.

- 1 Heat supply (fuel or recovered heat)
- 2 Boiler/steam generator
- 3 Exhaust
- 4 Steam turbine
- 5 Electricity production
- 6 Condenser
- 7 Cooling tower

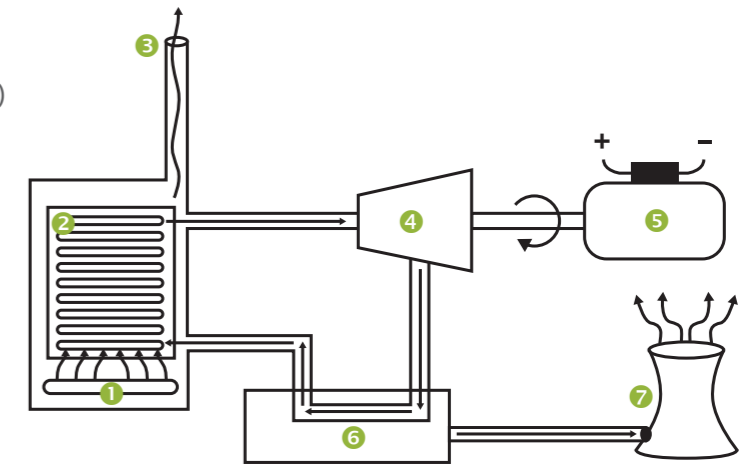

The steam expands in the steam turbine (from high pressure to low pressure) and makes the turbine turn. Through this expansion, the potential energy (in the form of high pressure and high temperature steam) is converted into kinetic energy (rotation of the turbine).

The steam is guided against a row of rotor blades, which makes the steam change direction, and puts the rotor into motion as a reaction. Then the steam is guided along a row of stator blades, where the flow changes direction again and is sent to the next row of rotor blades.

This process is repeated until the steam is expanded to a maximum. When the steam energy is exhausted so far that water droplets begin to form, it is led out of the turbine. Water drops that hit the turbine blades at high speeds, cause erosion.

The impeller (on which the rotor blades are mounted) rotates around its axis and performs mechanical work. This axis drives an electric generator.

The water is then led back to the boiler by the feed pump and the cycle resumes.



Additional heat energy can be recovered from either the outlet of the turbine or from a draw-off from the turbine.

## CONDENSING TURBINE

The condensing turbine lets the high pressure steam expand completely (up to 0,1 - 0,2 bar) using a condenser that creates underpressure. This is to obtain a maximal electricity output. The condenser maximizes the energy extracted from the steam by creating a lower pressure (through cooling) and “sucking” the high pressure steam through the turbine.

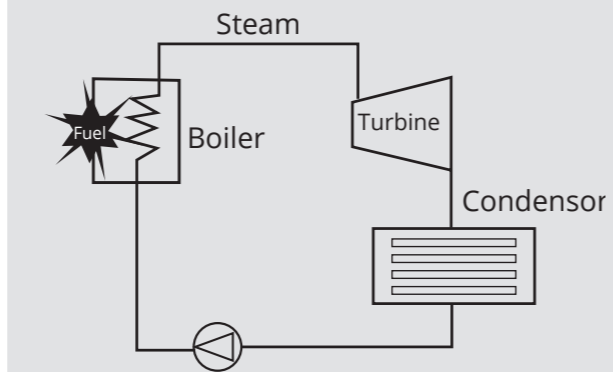

CONDENSING TURBINE

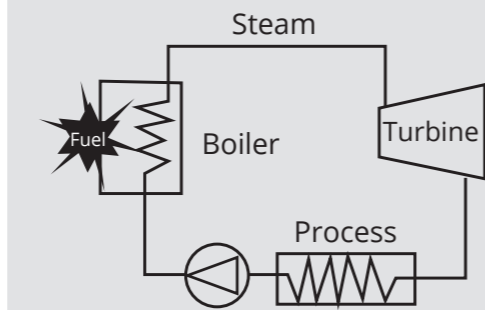

BACK PRESSURE TURBINE



## BENEFITS

- ✓ Good efficiencies
- ✓ Flexible power/heat ratio
- ✓ Water as working fluid
- ✓ Saving primary energy and reduction of CO<sup>2</sup> emissions
- ✓ Free electricity
- ✓ More independency of the volatile electricity market
- ✓ Long lifetime: about 20 years
- ✓ Proven technology
- ✓ Unattended operation
- ✓ Reliable

## EFFICIENCY

The efficiency of a steam turbine is determined by the conditions of the produced steam (pressure and temperature) at the inlet, the efficiency of the turbine and the outlet steam conditions. Usually, the electrical efficiency lies between 8% and 22% for small steam turbines. Using a back pressure turbine, heat and power are produced simultaneously. The electrical efficiency for this application is slightly lower, but the thermal efficiency is 60 to 80%, which makes the overall efficiency considerably higher when the heat is used.



## APPLICATIONS

With a power range from 100 kWe to 5 MWe, Upgrade Energy enables electricity generation, from tailor-made solutions for local electricity consumption to power plants that supply electricity to the grid.

### Industries:

- Food
- Distilleries
- Petrochemical
- Pulp and paper
- Construction materials
- Textile
- Chemical
- Municipal waste
- Biomass
- Litter

### The steam source can be

- Biomass boiler
- Excess steam from a production process
- Hot flue gasses
- An oversized boiler
- Waste incineration process



## REFERENCE CASE



Client	Philbest canning
Industry type	Food
Capacity	275 kWe
Inlet steam	100-300 psig
Commissioning	2018

## CONCLUSION

A steam turbine system generates electricity from steam. For every kWh of fuel consumed (or waste heat recovered), the steam turbine generates more valuable electricity. As a part of a sustainable and environmental policy, the steam turbine technology reduces primary energy consumption (fossil fuels). With local electricity consumption using a steam turbine, your business contributes to a greener future, in an economically viable way.





# ENERGY STORAGE

## ELECTRIC BATTERIES

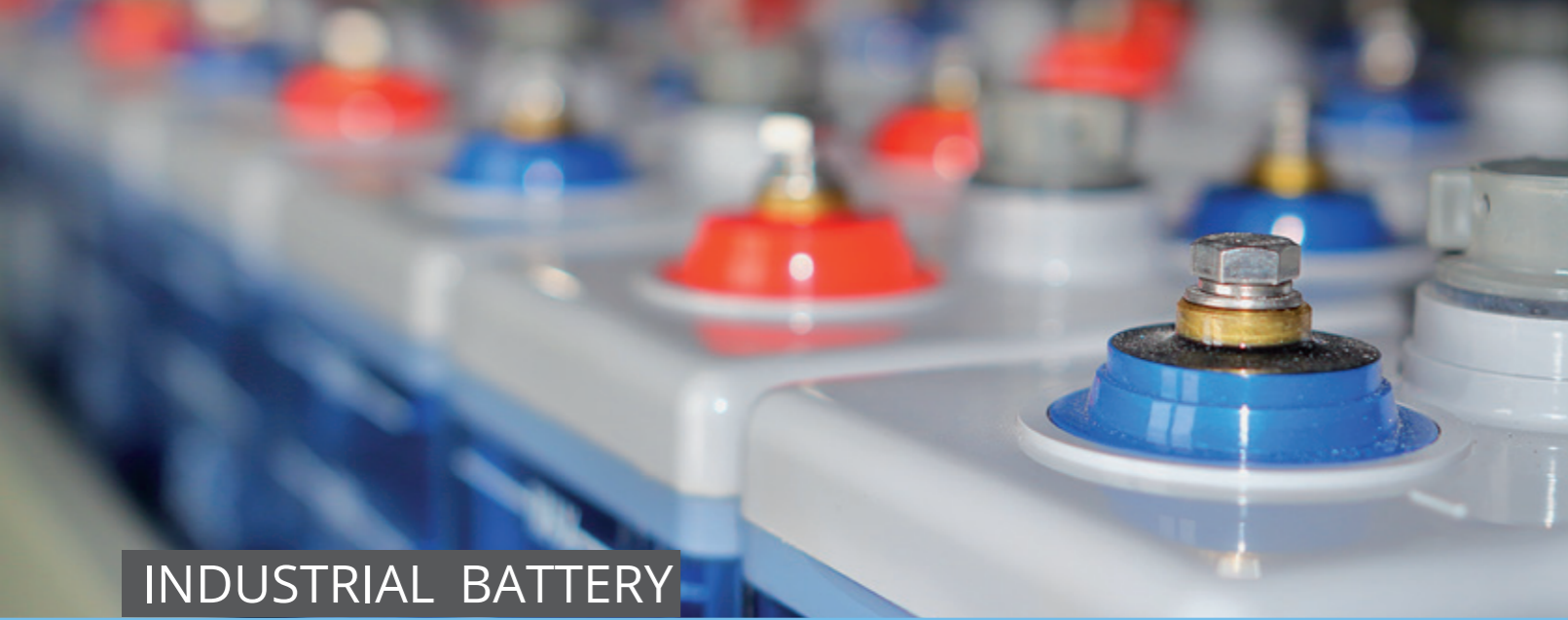

## INDUSTRIAL BATTERY

### WHAT IS IT?

An industrial rechargeable battery is used to repeatedly store electricity and release it at a required voltage (V) and power (kVA), for on-site consumption.

It can supply energy to an entire facility over a specific period of time.

Industrial batteries have the ability to charge and discharge at any time. This enables charging during low electricity tariffs and discharging during expensive tariffs. It also enables a flexible use of variable solar and wind energy.

Intelligent load and energy management keep the system running even in difficult situations, providing immediate and high backup power to keep your plant running at the most critical moments. A battery provides continuous load variations without efficiency loss.

### TYPICAL IMPLEMENTATION

The energy storage system is typically implemented with the following components:

- External power sources (PV, grid, generator, combinations, ...)
- Charger/inverter(s) (PCS)
- Battery pack
- The load (consumers)
- Energy management system (EMS)

Other implementations:

- Without grid
- Without solar energy
- Without generator

Only (minimum) 1 power source is needed.

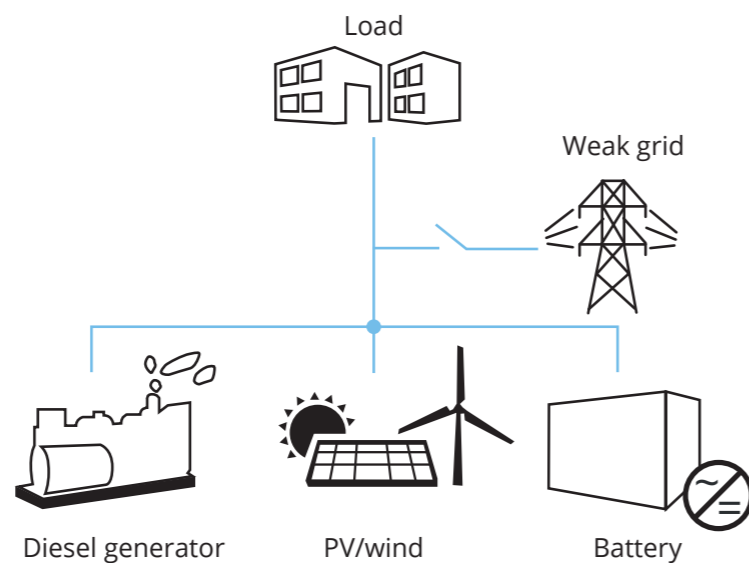
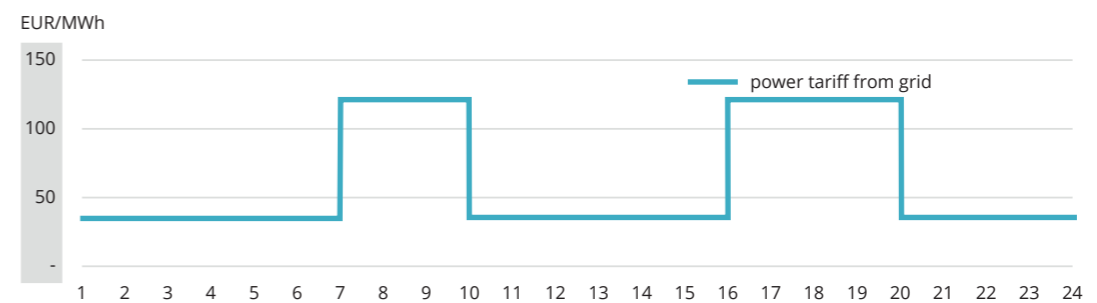
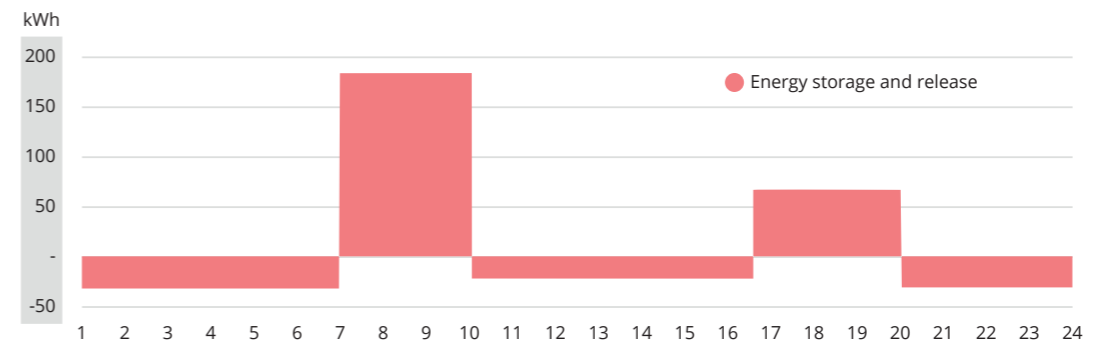
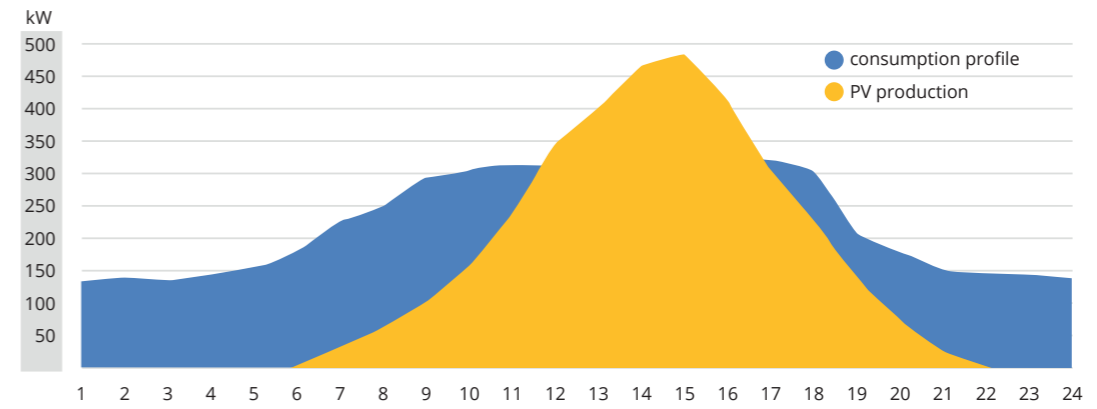

### BATTERY LIFE

Battery life is typically defined as the number of full charge-discharge cycles before significant capacity loss occurs.

As a battery discharges, its voltage gradually diminishes. When depleted below the protection circuit's low-voltage threshold (2.4 to 2.9 V/cell, depending on chemistry) the circuit disconnects and stops discharging until recharged.

Upgrade Energy installs batteries that have at least 80% of their initial capacity after 4000 cycles, such as high quality Li-ion batteries. Some batteries based on carbon anodes offer more than 10,000 cycles.

### PERFORMANCE

The D.O.D. (= depth of discharge) is the maximum allowed amount of discharge, expressed as a percentage of the battery capacity. This is usually around 90%. A 1000 kWh battery pack can discharge approximately 900 kWh. This equals e.g. 900 kW of power during 1 hour or e.g. 450 kW over 2 hours.







## APPLICATIONS

### INVERTERS

The battery inverters (PCS) transform AC (alternating current) power to DC (direct current) power, in order to charge the battery. Usually a bi-directional inverter is used, combining the power transformation during charging and discharging (DC back to AC) in one component. Upgrade Energy uses inverters with the highest efficiencies.

### HOUSING

The battery pack is integrated in an enclosure with air conditioning (filtering, drying and cooling). This ensures a clean environment inside the housing and a longer life time of the battery cells. The housing is also equipped with fire detection, sprinklers, lighting, electronics & communications technology, ...

### BENEFITS

- ✓ Enables choice in power tariff
- ✓ Energy security
- ✓ Grid stabilization
- ✓ Benefitting more from renewables
- ✓ Durable and proven technology
- ✓ Long life span installation: + 25 years
- ✓ Voltage support
- ✓ Automated switching between grid and island mode
- ✓ Response to frequency deviations in milliseconds
- ✓ Cos φ?? compensation
- ✓ Flexible charging and discharging
- ✓ Low maintenance
- ✓ Inside/outside installation
- ✓ No moving parts
- ✓ No noise (interesting for hotels, hospitals, resorts, ...)
- ✓ Easy installation

### UPGRADE ENERGY OFFERS

- ✓ We design energy storage solutions tailored to your needs.
- ✓ We install and connect the unit at your facility, using high quality materials, from certified suppliers.
- ✓ We take care of monitoring and maintenance.

.... so you can focus on your core business.

We offer a range of energy storage systems from 100 kWh up to 20 MWh.

- **Time shifting**
  1. Peak tariff reduction: Some energy providers increase their tariffs during specific hours of the day. To minimize the electricity bill, the battery is charged during low tariff and discharged again during peak tariff.
  2. Peak shaving: The battery captures the excess PV production during the day, and releases it in the evening or at night.
- **Weak grids:** When there are multiple heavy consumers on the same grid, the grid can have effect of voltage variations and frequency fluctuations, which are troublesome for your loads. A battery stabilizes these variations and therefore decreases damage to your loads. This increases their life span.
- **Unreliable supply:** Batteries compensate for black outs of the grid. They provide your plant with immediate back-up power. This eliminates losses due to down time and wasted products.
- **Fuel saving:** The battery smooths out the load variations which decreases the fuel consumption of your generators, by keeping them running at a constant power. This increases their life span and decreases maintenance. The battery management system can also turn your generators on and off in function of the PV production and the required load at specific times.
- **Off-grid applications:** the battery works as a baseload power supply. It is charged with an on-site power source: solar panels or a generator
- **Bandwidth reduction:** By reducing the peaks in the consumption profile, the consumers bandwidth can go under a certain level. This makes power supply easier for the grid company, and can enable lower tariffs.

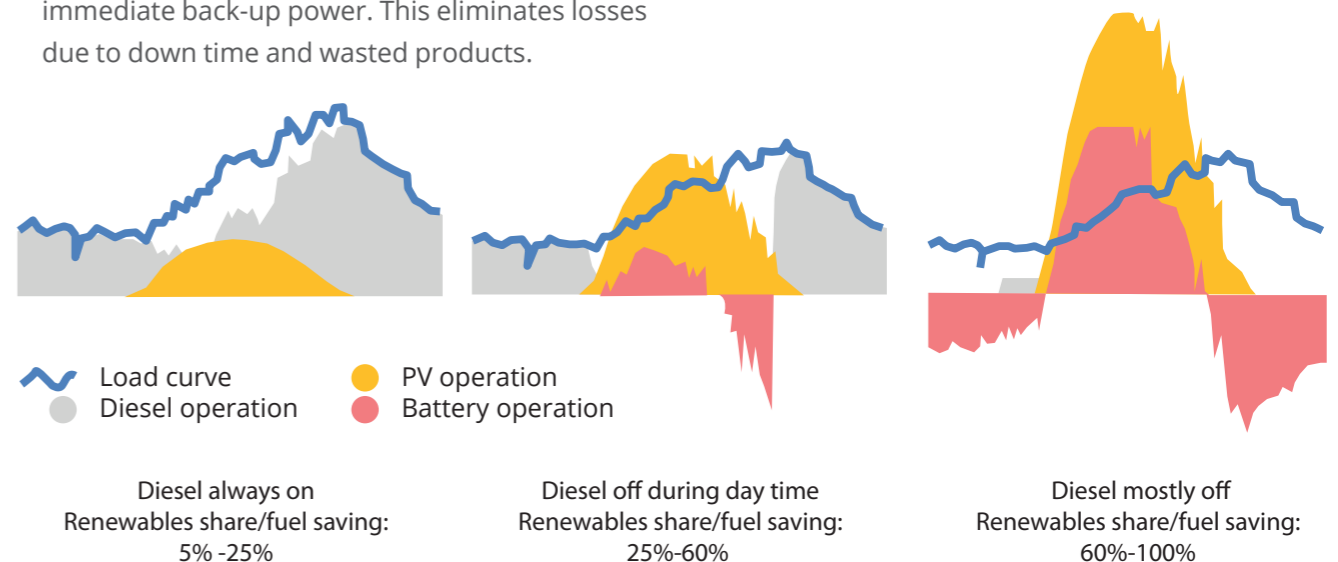

## EXAMPLE CASE

Time shifting - For a client who pays 4 to 5 times more during peak-tariff than during normal tariff, a 750 kWh battery generates up to € 110 172 savings per year.

Considering an investment of approximately € 390 000, this installation is paid back in 3,5 years.

Electricity tariffs		
normal tariff	0,035	EUR/kWh
peak tariff	0,165	EUR/kWh

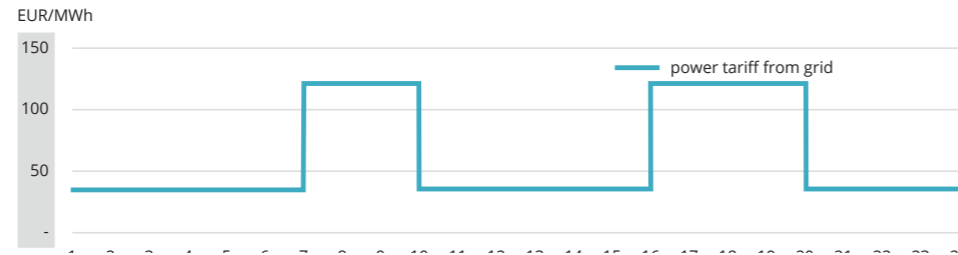

Current consumption [kWh]				Current cost
Month	During normal tariff	During peak tariff	Total	Total
Jan	357.885	80.228	438.113	€ 25.764
Feb	290.590	65.127	355.717	€ 20.917
March	283.200	63.822	347.022	€ 20.443
April	366.565	80.173	446.738	€ 26.058
May	341.280	75.559	416.839	€ 24.412
June	367.320	80.399	447.719	€ 26.122
July	422.831	87.320	510.151	€ 29.207
Aug	390.911	83.376	474.287	€ 27.439
Sept	380.982	69.543	450.525	€ 24.809
Oct	391.558	79.623	471.181	€ 26.842
Nov	370.454	81.716	452.170	€ 26.449
Dec	360.187	71.156	431.343	€ 24.347
Year total	4.323.763	918.042	5.241.805	€ 302.809

New consumption [kWh]				New cost
Month	During normal tariff	During peak tariff	Total	Total
Jan	460.019	0	460.019	€ 16.101
Feb	373.503	0	373.503	€ 13.073
March	364.373	0	364.373	€ 12.753
April	469.075	0	469.075	€ 16.418
May	437.681	0	437.681	€ 15.319
June	470.105	0	470.105	€ 16.454
July	535.659	0	535.659	€ 18.748
Aug	498.001	0	498.001	€ 17.430
Sept	473.051	0	473.051	€ 16.557
Oct	494.740	0	494.740	€ 17.316
Nov	474.779	0	474.779	€ 16.617
Dec	452.910	0	452.910	€ 15.852
Year total	5.503.895	0	5.503.895	€ 192.636

## CONCLUSION

With an energy storage system (ESS), energy costs are reduced by discharging (cheaper) electricity from your battery at moments when it is needed the most. It increases power quality, flexibility, energy security, voltage stabilization and easily integrates renewables.

A battery is especially interesting for hotels, hospitals, resorts, factories with an unstable energy supply, facilities with a tariff difference, facilities running on generators, remote areas such as mining facilities, ...

Upgrade Energy designs and installs energy storage systems at your facility, to help you increase grid independence and lower your overall energy costs.





# INDUSTRIAL HEAT PUMP

## UPGRADING LOW GRADE HEAT



## HEAT PUMP

### WHAT IS IT?

A low temperature waste heat flow can be upgraded to a useful high temperature heat through the use of a heat pump.

### WORKING PRINCIPLE

The operating principle is based on compression and expansion of a working fluid, or a so called 'refrigerant'. A heat pump has four main components: evaporator, compressor, condenser and expansion device. The refrigerant is the working fluid that passes through all these components. In the evaporator heat is extracted from the heat source, by evaporating the working fluid. In the condenser this heat is delivered to the heat consumer at a higher temperature. Electric energy drives the compressor which increases the energy content of the working fluid going to the condenser.

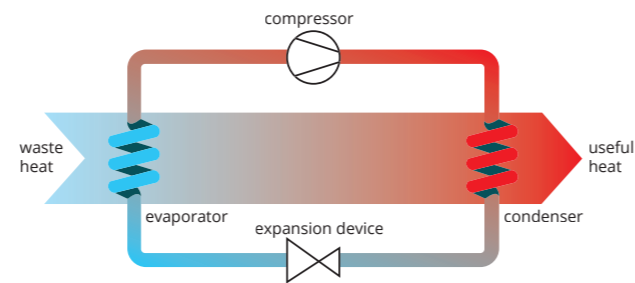

### THERMODYNAMIC CYCLE

The operating principle of a heat pump is based on the physical property that the boiling point of a fluid increases with pressure. By lowering the pressure, a medium can evaporate at low temperatures while an increase of pressure will lead to a higher boiling point. The black line in the graph shows the relation between pressure and the corresponding boiling point of, in this case, Ammonia. At low pressure and temperature Ammonia is evaporated in the evaporator. The energy needed for this is provided by a waste-heat flow. The

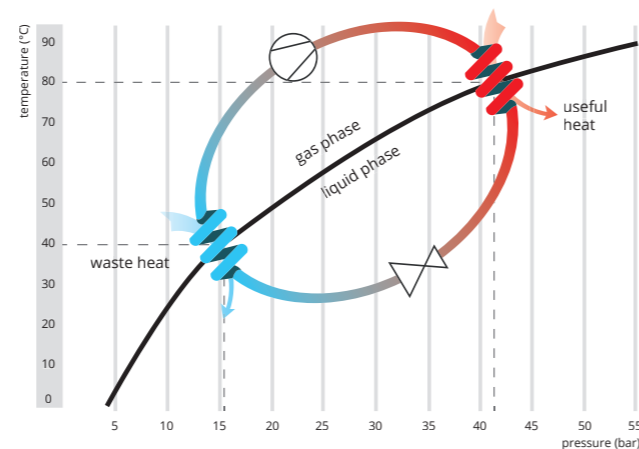

compressor increases the pressure of the Ammonia vapor. The vapor is then condensed at high pressure and temperature inside the condenser. During the condensation of Ammonia, heat is released: a useful source of energy. The liquid Ammonia is transported to the expansion device that lowers pressure. The low temperature, low pressure Ammonia flows to the evaporator: the starting point of yet another cycle.

### REFRIGERANT

The figure shows the heat pump cycle for the refrigerant Ammonia. For large scale industrial applications, Ammonia is the most suitable refrigerant for heat pumps that deliver heat up to a temperature of 90 °C. The choice of refrigerant for a certain application is determined by the temperature range of its thermodynamic cycle, environmental, legal obligations and the size of the needed installation. Refrigerants are divided into two groups: natural refrigerants (Butane, Ammonia, CO<sub>2</sub>) and synthetic refrigerants (R134A, R407C, R410A).

### COEFFICIENT OF HEAT PERFORMANCE (COPH)

The efficiency of the heat pump is denoted by its COPh (coefficient of heat performance), defined as the ratio of the total amount of heat delivered by the heat pump to the amount of electricity needed to drive the heat pump. The COPh varies from 4 to 15, depending on the temperature difference between waste heat source and heat consumer: the smaller the difference, the higher the COPh.

An increasing evaporation temperature increases the COPh. A decreasing condensation temperature, decreases the COPh: In general the COPh decreases with an increase in temperature difference between condensation and evaporation point.

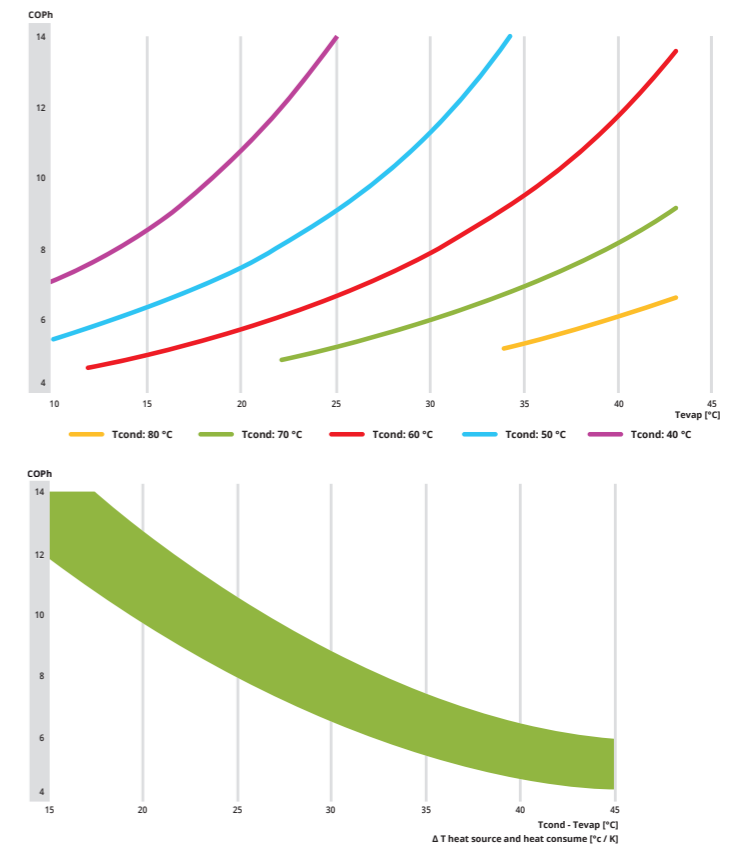

### BENEFITS

- ✓ Savings on fuel costs due to very high efficiencies
- ✓ By saving primary energy, less CO<sub>2</sub> is emitted, for the same energy performance.
- ✓ Proven and sustainable technology
- ✓ Waste heat is transformed into useful heat



## APPLICATIONS

The heat pump pumps up the temperature of

- Residual process heat exhaust gasses, water or thermal oil
- Geothermal heat
- Outside air
- Heat from solar collectors
- Excess heat from a cooling circuit (process or engine cooling)

## SOME EXAMPLES

### 1 DRYING PROCESSES

The most common dryer type is one in which air is heated with steam, gas or hot water and then circulated over the wet product. As the air picks up moisture from the wet product, its humidity increases and the energy contained in this stream may make it a useful heat source. The standard procedure is to exhaust this humid air or dehumidify it. With a heat pump however, heat is extracted from the humid air. The air is cooled down and dehumidified. The extracted heat is increased in temperature and is used to heat the dryer.

In drying applications, the use of a heat pump serves two purposes:

1. heating the dryer and
2. dehumidifying the air

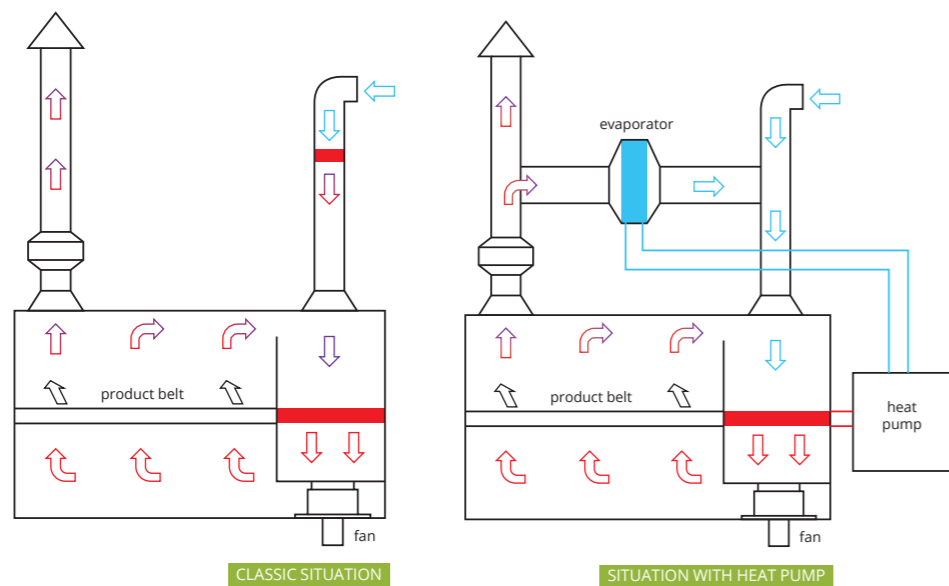

### 2 WASHING PROCESSES

Hot water, sometimes mixed with a solvent, is sprayed over a product. A washing installation is often equipped with an air discharge fan to avoid vapor flowing out through the in- and outlet opening and other openings in the washing machine. The air discharge will blow humid, hot air to the surroundings and will maintain an under pressure situation inside the washing machine. The discharged air contains a large amount of energy. With a heat pump it is possible to use this energy to heat the washing water.

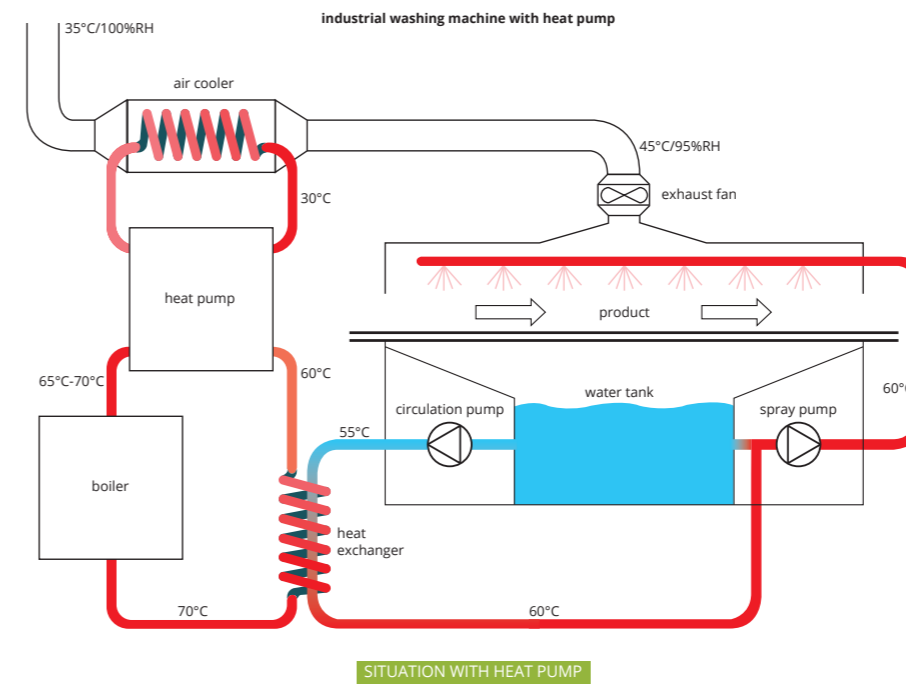
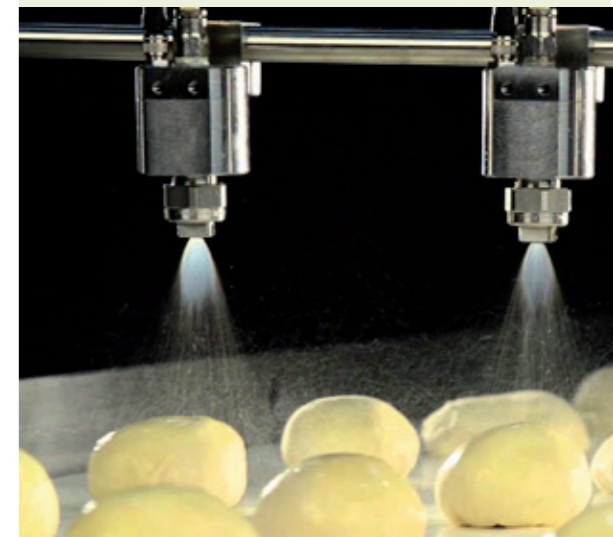

SITUATION WITH HEAT PUMP

### 3 HEAT FROM A REFRIGERATION SYSTEM

Typically the food industry produces products that need to be cooled or frozen before transport and/or consumption. For this process and for cleaning purposes, hot water is needed. Waste heat from a refrigeration system has a temperature of 25 to 30 °C. With the use of an add-on heat pump, waste heat from the condensing side of the refrigeration system can be used to heat water to temperatures up to 80 °C.

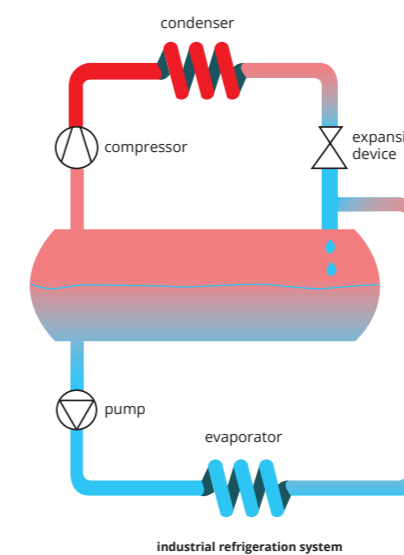

CLASSIC SITUATION

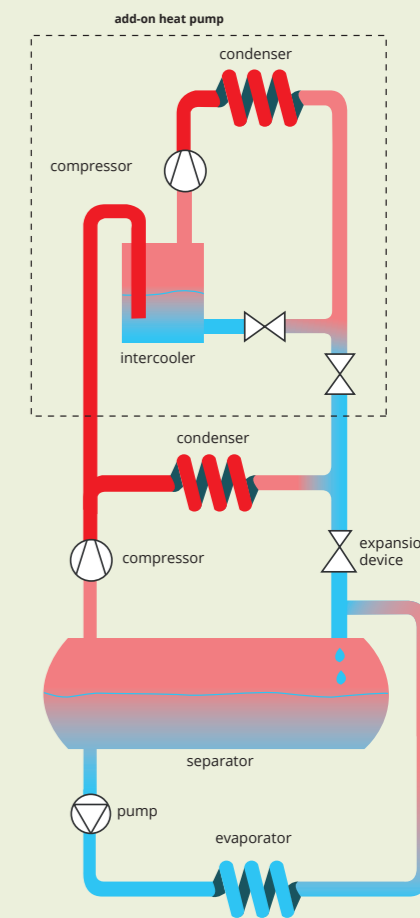

SITUATION WITH HEAT PUMP

## 4 PASTEURIZATION

For pasteurization a product needs to be heated above 70 °C. Afterwards the product is cooled down. The product temperature thus varies from cold before pasteurization to hot during pasteurization and back to cold again. In most pasteurization processes the heat exchange between the cold and hot product flow is already implemented. The cold product before pasteurization is used to pre-cool the product directly after pasteurization, or looking at it the other way around: the hot product is used to pre-heat the cold product. In addition to this, extra heating and cooling is needed for pasteurization. This is normally provided by, for example, steam injection and a flow of chilled water. A heat pump however, extracts heat from the product that needs to be cooled and supplies this heat at a higher temperature to the product that needs to reach pasteurization temperature.

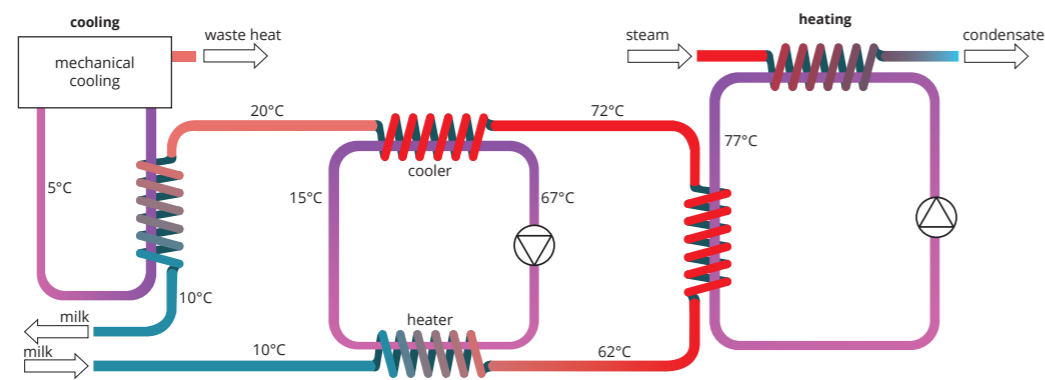

CLASSIC SITUATION

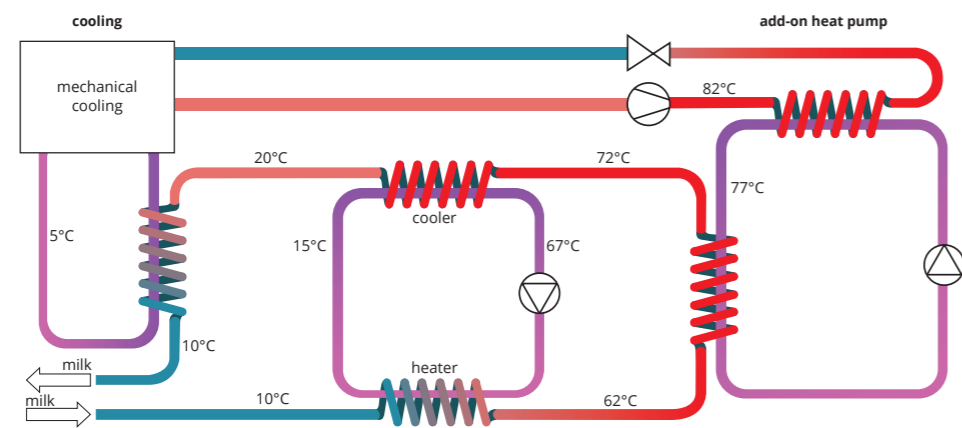

SITUATION WITH HEAT PUMP

## REFERENCE

Client	XPO logistics/Norbert Dentressangle
Industry type	Logistic sector
Heat source	Outside air
Heat application	Building air heating
Total capacity	180 kWth
Commissioning	2016



## CONCLUSION

For every kWh electricity a heat pump consumes, it produces 4 to 15 times more kWh's of heat. As a part of a sustainable and environmental policy, heat pump technology turns unused energy into useful energy, which reduces your overall energy consumption.

With the industrial heat pump technology, your business contributes to a greener future, in an economically viable way.





# RELIGHTING

ENERGY EFFICIENT LIGHTING

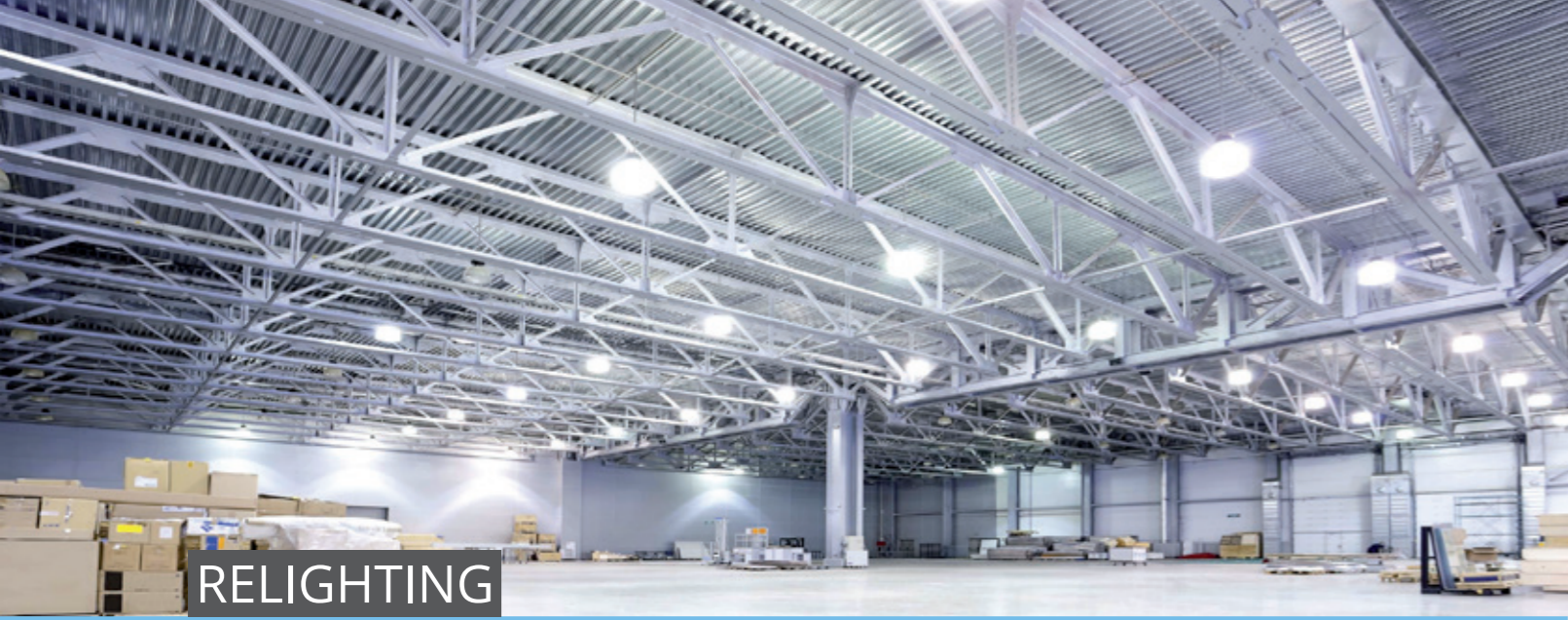

## RELIGHTING

### WHAT IS IT?

Relighting is the replacement of your lighting by more energy-efficient LED alternatives.

### WHY?

With relighting 40 - 80% of electricity consumption is reduced for the same (or better) light performances.

Since April 13th, 2015 high pressure mercury lamps are banned by the European Commission. They are no longer allowed to be sold and they are no longer available in the European market.

### SOLUTION

Upgrade Energy replaces your existing lamps by LED alternatives, while improving the light quality and comfort.

By saving electricity, relighting projects are payed back in 0,5 to 3 years, depending on the amount of burning hours/year.

Upgrade Energy offers:

- Light study
- Installation and project management
- CE conformity guarantee
- 5 year warranty on all lamps
- Third party investment: this allows companies to benefit immediately from energy savings without investing

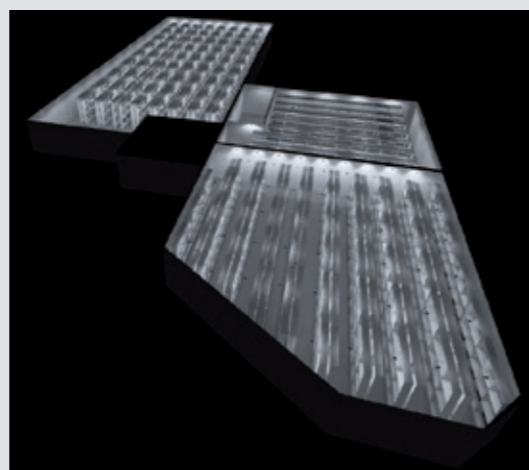

## LED ALTERNATIVES

1. The « high bay » alternatives replace high pressure mercury lamps



2. LED tubes replace TL lamps (all sizes)



3. LED panels also replace TL lamps. They are often used in office buildings and commercial areas.



4. Upgrade Energy also offers alternatives for big spots, halogen spots, outdoor lights, ...



## REFERENCE CASE

Client	Van Moer, Belgium
Industry type	Logistics
Installed capacity	277 x 150 W = 41,5 kW
Electricity savings	45%
Commissioning	2016

## CONCLUSION

Relighting saves 40 - 80% of electricity consumption for lighting. As a part of a sustainable and environmental policy, relighting saves primary energy consumption. By relighting, your business contributes to a greener future, in an economically viable way.





# PHOTOVOLTAIC POWER PLANT

ELECTRICITY FROM SOLAR ENERGY



# SOLAR ENERGY

## WHAT IS IT?

Solar energy is a source of renewable energy, a photovoltaic powerplant transforms radiation energy from the sun into useful electricity. The generated electricity is used on-site or (partially) injected into the grid.

A solar installation consists of solar panels, a mounting system, solar cables and inverters. The panels are installed on a rooftop or on the ground by the mounting system.



ROOFTOP INSTALLATION



GROUND INSTALLATION

## WORKING PRINCIPLE

The solar panels capture the sun's energy using photovoltaic cells that convert sunlight into DC (direct current) power. The DC current is transformed into useful AC (alternating current) power by inverters. This current is then fed to the AC main electricity supply of the building. The kWh meter measures the amount of energy produced. These measurements are logged in order to follow the electricity production of the photovoltaic installation at all times (and check data from the past).

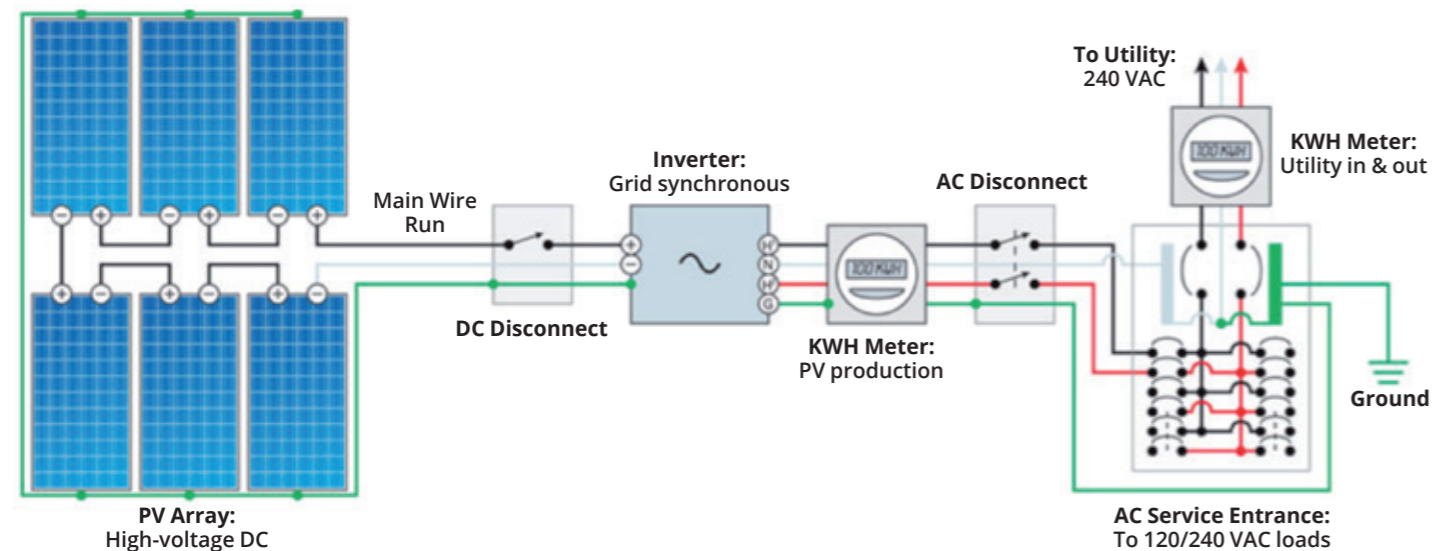

## ELECTRICITY OUTPUT

The power generated by the PV (photovoltaic) installation depends on:

- The amount of sunlight that falls in on the panels
- The outside temperature
- The performance of the installation

## THE AMOUNT OF SUNLIGHT

The PV panels produce energy most efficiently when the solar radiation is perpendicular to the panel's surface.

The amount of sunlight that reaches the solar panels is optimized by choosing the perfect orientation of the panels towards the sun. Since the earth moves with respect to the sun, the rays of light hit the panels in different angels throughout the day and throughout the year.

The PV panels should always face towards the equator. In the northern hemisphere the panels face south and are tilted with the northern side up to an angle approximately equal to the site's altitude. For example, if the system were located in Brussels (Europe), the PV panel should face south and tilt up at an angle of approximately 35° to capture the most sunlight through the year.

Secondly, trees, large buildings, or other structures or obstructions surrounding the site might cast shadows on the PV panels at various times of the day and during winter months when the sun is low. Therefore, the location of the PV installation must be chosen carefully.

The optimal tilt angle for a PV panel in the winter differs from the optimal tilt angle for the summer. Therefore the optimal tilt is calculated taking into account the angle of the sun over the entire year.

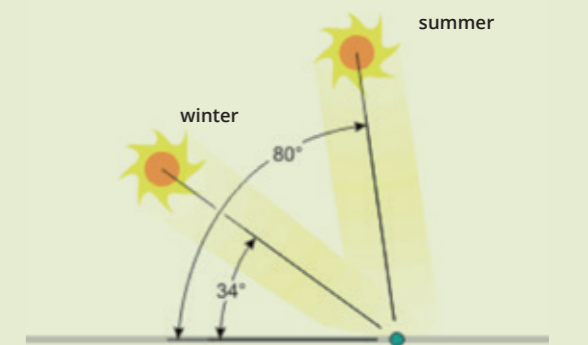
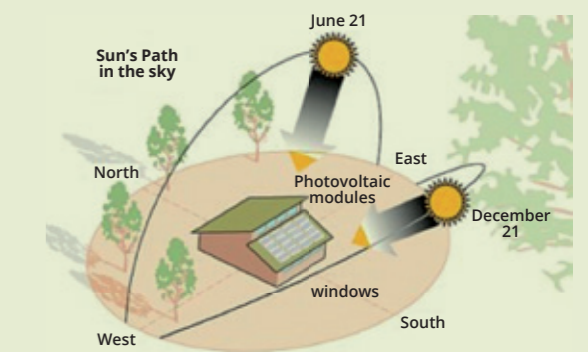
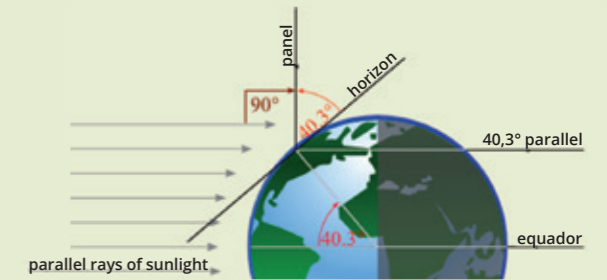
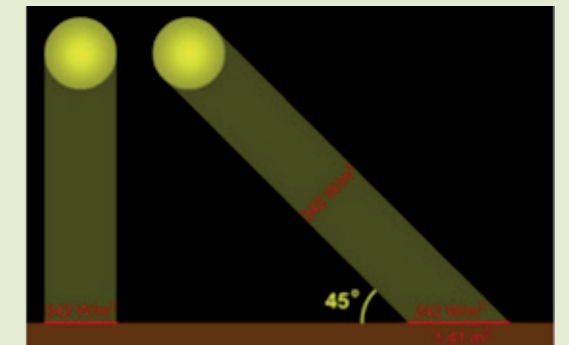



## APPLICATIONS

### TEMPERATURE INFLUENCE

PV installations produce more energy when it is cold outside. When the temperature decreases by 1 °C, the PV panel voltage increases by 0.12 V (for polycrystalline PV panels): The temperature coefficient for these panels is 0.12 V/C. This means that for a PV panel (with an open circuit voltage at standard conditions = 41,3 V) the voltage output increases with 3% , when it gets 10°C colder.

### INSTALLATION PERFORMANCE

Upgrade Energy uses high quality materials, from certified suppliers. The total of systems losses are limited to 10%.

### EXAMPLE CASE

A 1000 kWp PV ground installation in Milan with the following properties, generates 1 330 000 kWh of electricity per year.

- Location: 45°27'55" North, 9°11'9" East
- Elevation: 135 m.a.s.l.
- Type: Fixed system (crystalline silicon)
- Inclination: 36°
- Orientation: -2°
- Space occupation: 1,6 ha
- Weight rooftop installation: 15 kg/m<sup>2</sup>
- Nominal power of the PV system: 1000.0 kW
- Estimated losses due to temperature and low irradiance: 9.3%
- Estimated loss due to angular reflectance effects: 2.7%
- System losses (cables, inverter etc.): 10.0%
- Combined PV system losses: 20.6%

Average monthly electricity production (kWh)

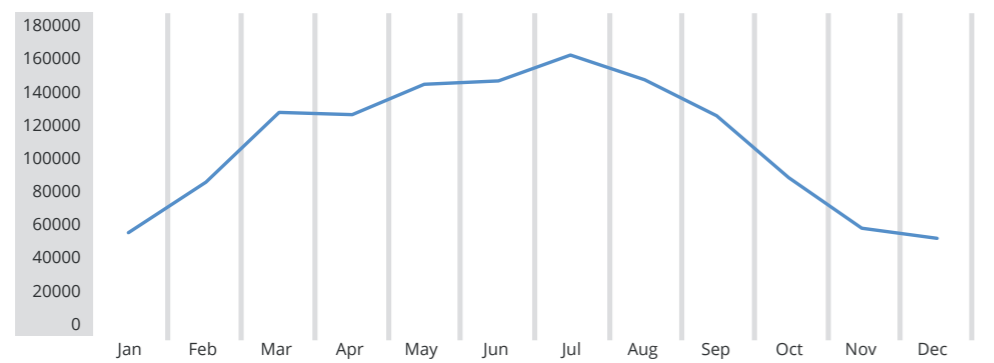

Solar energy is particularly interesting for companies and institutions that consume most electricity during the day.

Such as:

- The industrial sector
- The commercial sector
- The residential sector

Solar energy is also used for:

- Off-grid power supply
- Hybrid systems (combined with other energy sources)
- Battery charging during daytime
- Pumping up water during daytime

Upgrade Energy designs, installs and maintains PV installations of 50 kWp up to 10 MWp.

### BENEFITS

- ✓ Proven technology
- ✓ Long life span installation: over 25 years
- ✓ Economical energy supply
  - Low investment cost
  - Free energy source: the sun
- ✓ Low maintenance
- ✓ Environmentally friendly
  - No harmful waste or exhaust
  - No fuel consumption
  - No CO<sub>2</sub> emissions



## REFERENCES



73 clients in	Belgium, Turkey, Croatia, Philippines, Bosnia-Herzegovina and Eastern Europe
Type	Rooftop & ground installations
Total installed capacity	41 MWp

Example client	Winsa (Turkey)
Industry type	Plastics
Type	Rooftop
Capacity	650 kWp
Commissioning	2015

## CONCLUSION

With a PV installation, electricity is produced from a free and inexhaustible source.

It is a green, durable and low maintenance solution for generating electricity.

As part of a sustainable and environmentally friendly policy, solar power technology saves primary energy and decreases CO<sub>2</sub> emissions.

With a PV installation, your organization contributes to a greener future, in an economically viable way.





# GRID STABILISATION

## ENERGY MANAGEMENT SYSTEM

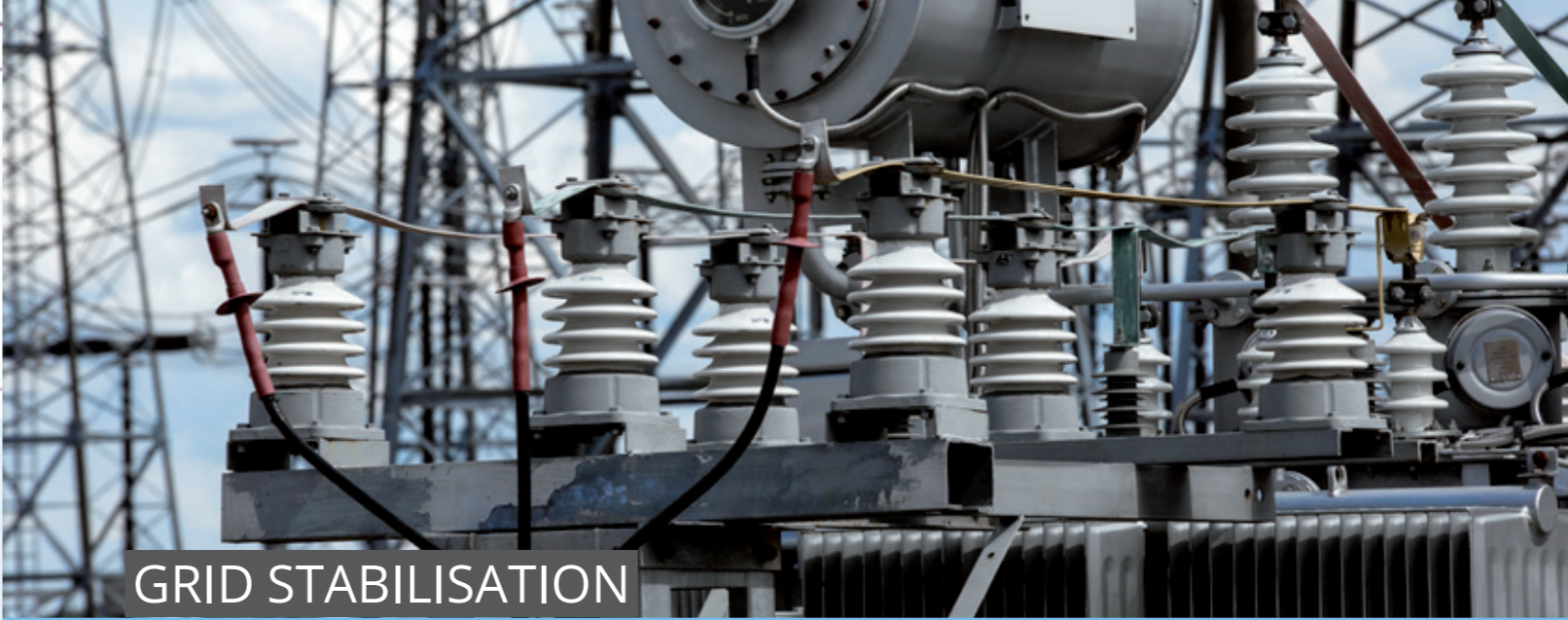

## GRID STABILISATION

### WHAT IS IT?

An grid stabilization system optimizes the use of the existing grid capacity and improves the power quality in terms of voltage stabilization and reactive energy minimization.

Voltage stability is essential to ensure efficient operation of the high-voltage grid. Upgrade Energy manages to maintain grid voltages at a suitable, stable level by using battery units that are connected to the grid.

By generating and absorbing reactive energy, the battery cells contribute to controlling and stabilising the grid voltage. The voltage stabilization helps keep the delivered voltage with e.g. 10% deviation of the voltage required by the power consumers (e.g. 400 V). This protects consumers' equipment and avoids consumers getting cut off the grid due to micro shortages.

In turn, this also causes lower current peaks, which lowers the losses.

### WHY VOLTAGE CONTROL?

Whereas the frequency in the grid is influenced by the behaviour of active energy, the voltage is affected by reactive energy. As active energy is very easy to transmit, frequency can be managed at national levels. Since reactive energy is harder to transmit, voltage has to be managed more locally.

The transmission of electrical power is subject to one particular principle of good practice: the voltage level must be as high as possible while the current must be as low as possible, within the limits imposed by the grid.

These conditions enable maximum power to be transmitted while minimizing energy losses and safeguarding the production units from ageing prematurely. However, the limited insulation capacity of the relevant lines and cables means that it is essential that the voltage in the grid does not exceed a certain level.

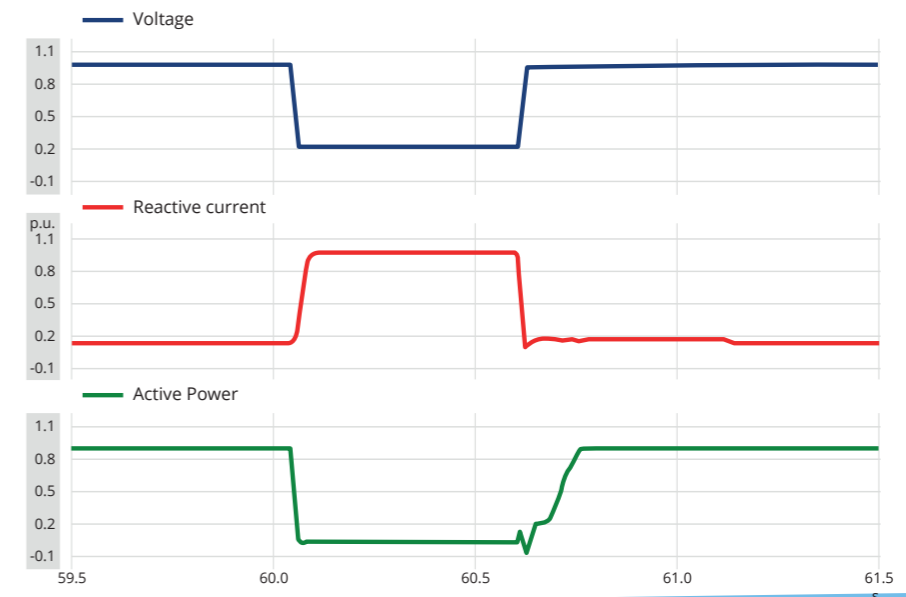

## SAVINGS

Grid stabilization helps save power and investments in different ways:

- ✓ Optimized use of the existing grid capacity
- ✓ No more damage to frequency regulators
- ✓ Less maintenance
- ✓ Power consumers experience less and lower current peaks. This enables less heat dissipation and smaller dimensioning of cables and actuators.
- ✓ Less micro shortages (a shortage of a few milliseconds can put a plant without power for multiple hours)

## BACK-UP POWER SUPPLY

The grid stabilisation system can provide backup power for local grids, villages or factories when the grid fails.

The energy management system switches to island mode and injects previously stored power back into the grid.

## MANAGING REACTIVE ENERGY

$\cos \varphi$  compensation is an adaptation method that reduces the phase shift in an electrical installation to an acceptable value. This is called improving or compensating the power factor. Such compensation is almost always carried out with capacitors, which are assembled into a capacitor battery. These capacitors can be integrated in the battery unit.

Voltage fluctuations in the grid are the effects of:

- The fluctuations in power demand and production that are caused by the offtakes and injections of nearby consumers and connections to other subgrids
- Electrical flows and topological changes in the grid.

The grid's reaction to such fluctuations is similar to a web, which must be supported by a flexible force so that it can withstand the tugging to which it is subjected. The battery buffers this tugging.

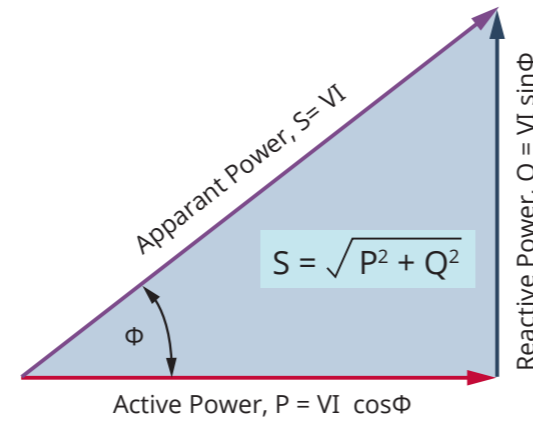
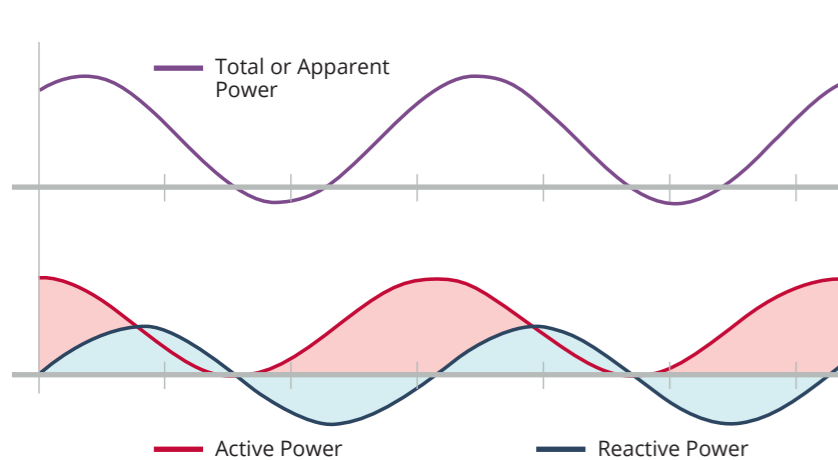

## COMPONENTS

The grid stabilisation systems consists of the following components:

- Battery pack
- Power conversion system (charging and discharging)
- Switchgear
- Grid measurement
- Coils
- $\cos \varphi$  compensator
- Monitoring and control system
- Air-conditioning, fire protection, lights, ...

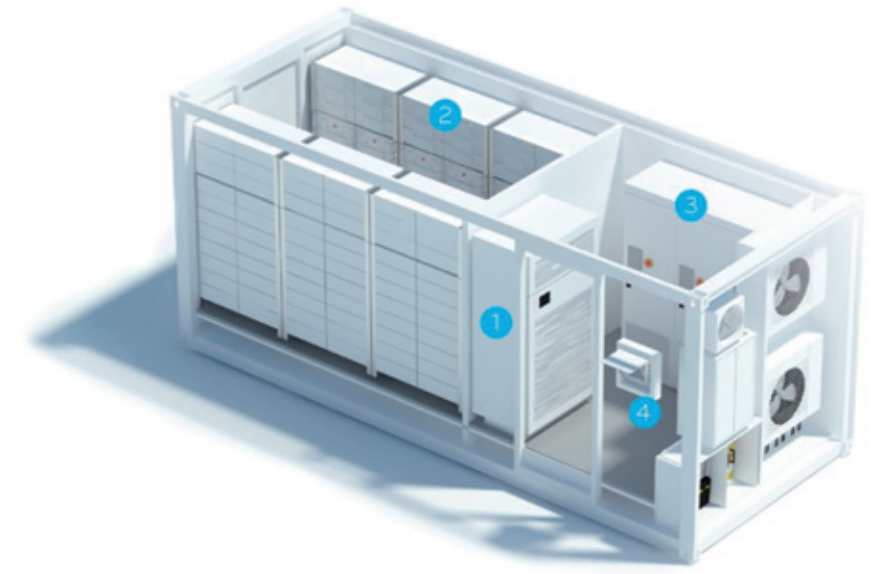

## BENEFITS

- ✓ Optimizing grid capacity
- ✓ Voltage support
- ✓  $\cos \varphi$  compensation
- ✓ Response to frequency deviations in milliseconds
- ✓ Energy storage
- ✓ Savings for power consumers
- ✓ Back-up and black start option
- ✓ Flexible charging and discharging power
- ✓ Can operate as external power source
- ✓ Low maintenance
- ✓ Durable technology
- ✓ Inside/outside installation
- ✓ Benefitting more from renewables
- ✓ Long life span: +25 years

- 1 The battery inverter  
Output: 50 kW - 6000 kW
- 2 Battery  
Capacity: 100 kWh - 30 000 kWh
- 3 PV inverter
- 4 Energy management control unit and monitoring



## APPLICATIONS

A grid stabilization installation is particularly interesting for

- weak /instable grids
- grids with black outs
- grids with renewables injection
- energy storage

Upgrade Energy designs, installs and maintains grid stabilization installations of 100 kWh to 30 MWh.



## CONCLUSION

Adding a smart battery pack (with  $\cos \varphi$  compensators) not only stabilises the grid by absorbing voltage fluctuations, it also

- Improves  $\cos \varphi$ , which reduces the reactive power and hereby enables optimal use of the existing grid capacity
- Can serve as energy storage system, which stores and releases larger amounts of energy when needed
- Can serve as power source during a black-out
- Is capable of a black start

Which

- Increases reliability
- Increases the quality and efficiency of energy production facilities on the grid
- Reduces costs related to power supply

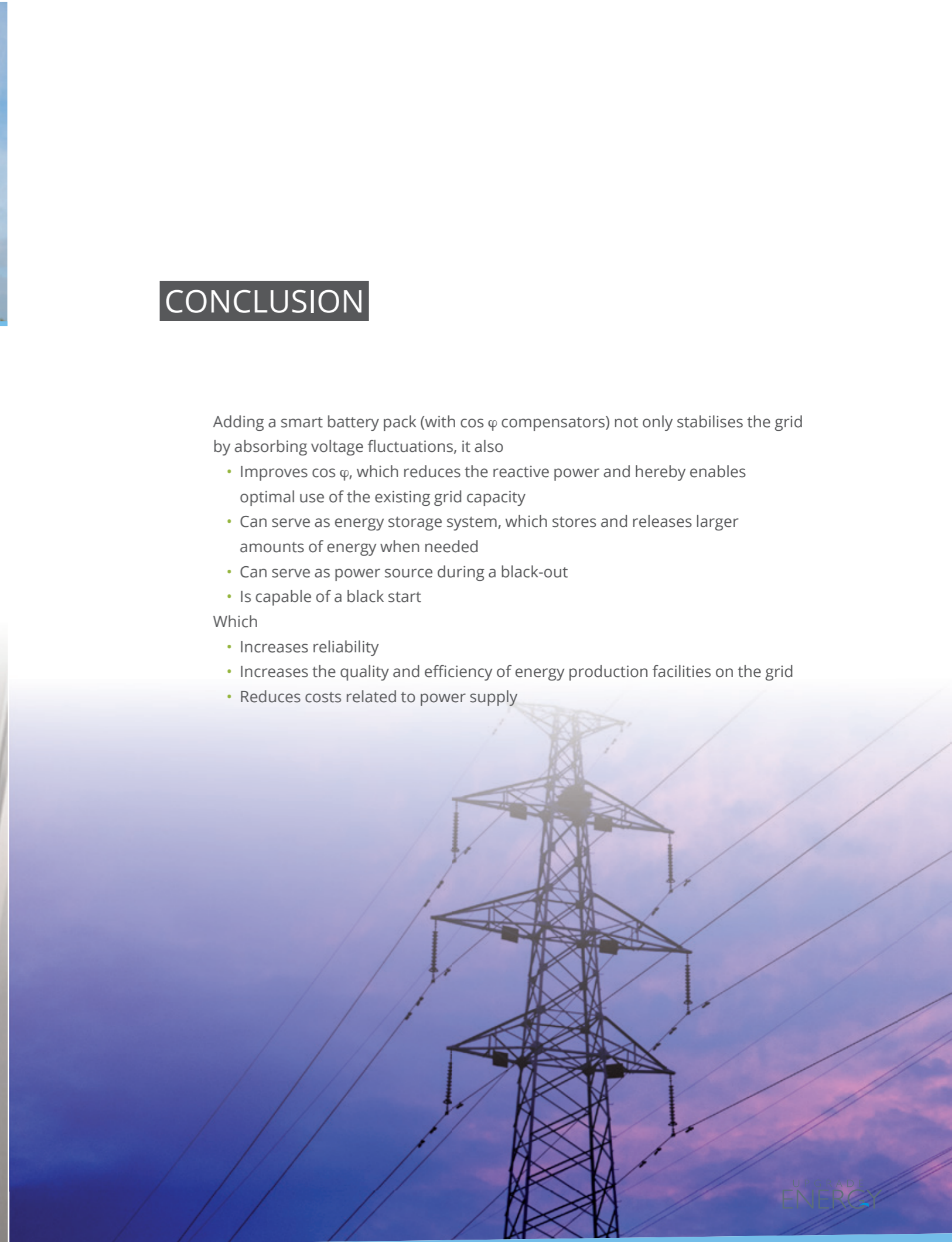





# WIND ENERGY

INEXHAUSTIBLE GREEN ELECTRICITY



## WIND ENERGY

### WHAT IS IT?

Wind energy is energy from moving air, caused by temperature - and therefore pressure - differences in the atmosphere. Irradiance from the sun heats up the air, forcing the air to rise and pressure to increase. Conversely, where temperatures fall, a low pressure zone develops. Winds (i.e. air flows) balance out the differences.

Hence, wind energy is solar energy converted into kinetic energy of moving air. Wind turbines capture the wind energy by converting the air flow into rotational movement, which subsequently drives an electric generator.

- |   |                                 |
|---|---------------------------------|
| 1 Foundation,                             | 7 Generator,                    |
| 2 Electric connection,                    | 8 Anemometer,                   |
| 3 Tower,                                  | 9 Electric or Mechanical Brake, |
| 4 Access ladder,                          | 10 Gearbox,                     |
| 5 Wind orientation control (Yaw control), | 11 Rotor blade,                 |
| 6 Nacelle,                                | 12 Blade pitch control,         |
|   | 13 Rotor hub                    |

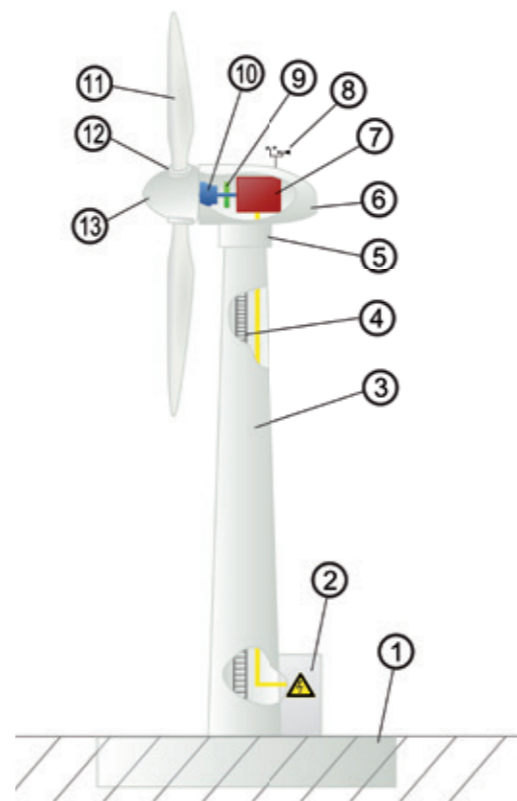

### WORKING PRINCIPLE

Wind turbines are designed to exploit the wind energy at a certain location, and transform it into electricity.

Horizontal axis wind turbines (HAWT) consist of three main components:

- The rotor component, which includes the blades for converting wind energy to low speed rotational energy.
- The generator component, which includes the electrical generator, the control electronics and the component for converting the incoming low speed rotation to high speed rotation suitable for supplying electricity to the consumer.
- The structural support component, which includes the tower and yaw mechanism.

Traditional horizontal-axis wind turbines have the main rotor shaft and electrical generator at the top of a tower, and use a wind sensor coupled with a servo motor, which positions the rotor shaft parallel to the wind direction. This allows the turbine to generate the most electricity possible from the available wind flow.

Aerodynamic modeling is used to determine the optimum tower height, control systems, number of blades and blade shape.

### DIRECT DRIVE TECHNOLOGY

Most wind turbines have a gearbox, which turns the slow rotation of the blades into a faster rotation that is more suitable to drive an electrical generator. But in our turbines the rotor directly drives the synchronous generator, without the use of a gearbox. This is called the direct drive technology.

This is important because the dominant cause of downtime of turbines is the malfunctioning of gearboxes. The generated energy is fed

to the grid or local power distribution via a modern back-to-back full-power converter which controls the output, so grid requirements can be met.

Advantages of Direct Drive Technology:

- Superior availability levels
- Lower maintenance costs
- No need to replace gearboxes
- Reduced noise levels
- Higher efficiencies / return on investment
- Lower cost of ownership
- Suitable to operate in weak grids



### BENEFITS OF WIND ENERGY

- ✓ Free source of energy: the wind
- ✓ Non exhaustible harvesting source
- ✓ No fuel consumption
- ✓ No CO<sub>2</sub> emissions
- ✓ Low maintenance
- ✓ Sustainable and proven technology
- ✓ More independence from the volatile energy market





## EXAMPLE CASE: 900 KW TURBINE



## APPLICATIONS



The technical specifications:

Rotor diameter	52 or 54m
IEC Wind Class	IIA & IIIA
Rotor speed	Variable: 12 - 28 rpm
Nominal (maximal) power output	900 kW
Available hub heights	35, 40, 50 and 75 m
Cut-in wind speed [1]	2.5 m/s
Rated wind speed	13 m/s
Cut-out wind speed [2]	25 m/s, 10 min. avg.
Survival wind speed [3]	59.5 m/s
Power output control	Pitch controlled variable speed
Generator	Synchronous multi-pole wound-rotor
Power converter	IGBT-controlled

[1] the wind speed referring to a specific blade-tip velocity, at which the wind turbine starts supplying useful output power at the shaft

[2] the wind speed referring to a specific blade-tip velocity, at which the wind turbine ceases to supply useful output power at the shaft

[3] the maximum wind speed that a turbine is designed to withstand before sustaining damage.

Wind energy is suitable for supplying additional electricity to your company and/or grid, in areas with an average constant wind speeds of 3 m/s or more.

Upgrade Energy builds wind turbines of 500 kW and larger.

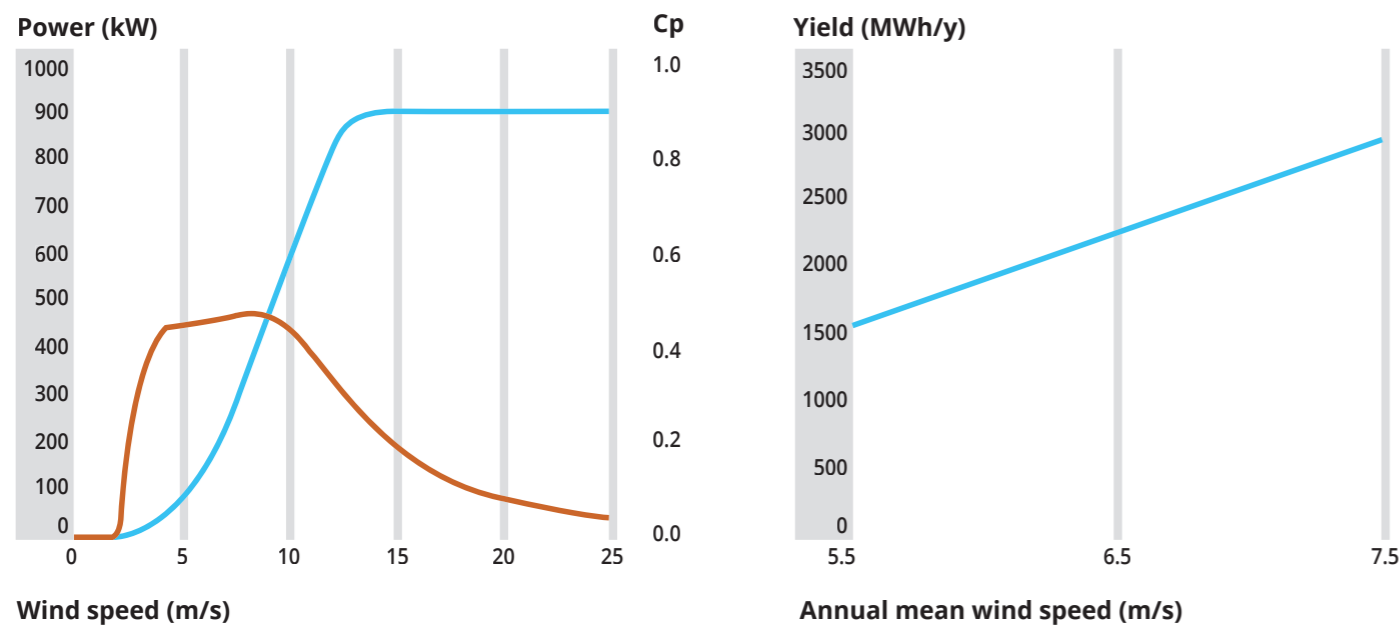

Depending on the wind speed, the turbine produces more electricity.

Cp (power coefficient) = the ratio of power extracted by the turbine to the total amount of energy contained in the wind resource.

### Typical wind turbine power output with steady wind speed

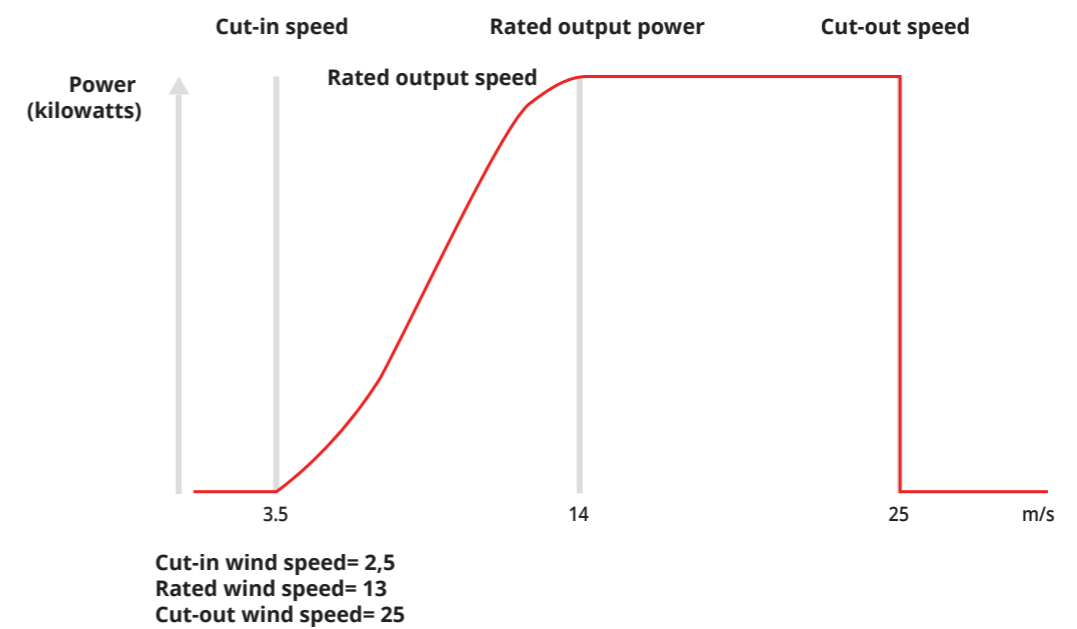

## REFERENCES

Realized wind energy projects (joint venture with partner)

Status	Country	Technology	Projects	Operational	Mw gross	MW net		
Installed	Belgium	Wind onshore	Brugge III	08/2004	12.6	12.6		
			Gistel	05/2007	2.3	2.3		
			Middelkerke	06/2007	0.8	0.8		
			Bastogne	02/2009	6.0	3.6		
			Leiedal wind	04/2009	8.0	6.0		
			Ieper	07/2009	4.6	4.6		
			Kallo	01/2010	2.3	2.3		
			Maldegem	12/2010	16.1	11.3		
			Brugge I	01/2011	1.2	1.2		
			Zedelgem	01/2011	1.8	1.8		
			Berlare	12/2011	9.2	4.7		
			Perwez II	12/2012	4.0	4.0		
			Menen	12/2012	4.6	2.3		
			Italy	Wind onshore	Pontedera	09/2008	8.0	8.0
			France	Wind onshore	Pielan le Grand (Rennes)	11/2008	12.0	7.8
					La Tourelle	08/2009	2.3	2.3
					Lanrivain	10/2009	8.0	8.0
					Beau Soleil	02/2010	10.0	10.0
					Croix des 3 Chesnots	02/2010	8.0	7.4
	Penquer II	09/2010			4.0	1.6		
	Penquer	09/2010			12.0	12.0		
	Landier du Rohallet	10/2010			8.0	8.0		
	Bulgaria	Wind onshore	Pigeon Blanc	11/2010	12.0	8.4		
			Shabla South	12/2011	4.0	4.0		
	South Africa	Wind onshore	Shabla North	02/2012	2.4	2.4		
			Coega	06/2010	1.8	1.8		
	Romania	Wind onshore	Topolog	12/2010	3.0	3.0		
	Ireland	Wind onshore	Ballycadden 5/9	12/2012	15.0	7.7		
	Total installed					184.0	149.9	



## CONCLUSION

As a part of a sustainable and environmental policy, wind energy supplies inexhaustible green electricity to your business/grid.

With wind energy, your organisation contributes to a greener future, in an economically viable way.





# SMALL HYDRO-ELECTRIC POWER PLANT

SUSTAINABLE ELECTRICITY PRODUCTION



## HYDRO-ELECTRIC POWER

### WHAT IS HYDRO-ELECTRIC POWER?

Hydro-electric power is electric power generated from the movement of water. The energy in the water is transformed into a rotational movement, by means of a turbine, which drives an electric generator. Small hydro-electric power plants are a source of low-cost and constant renewable energy. Since no fuel is used, and no CO<sub>2</sub> is emitted during the whole generation process and distribution of the electricity, hydro power is one of the most sustainable and green solutions for energy supply.

### WORKING PRINCIPLE

The potential energy in water, created through a height difference, called the head, is transformed into useful kinetic energy (speed) while it streams down. It is this kinetic energy that drives a water turbine and thus the electric generator.

The power extracted from the water depends on the time and the head, the height difference between the reservoir (forebay tank) and the power house, where the turbine is located.

Water is fed from the forebay tank through a pipe, called the penstock, into the turbine. The speed/pressure of the flowing water that falls on the turbine blades causes rotation of the turbine shaft.

The electricity produced by the generator (on the same shaft) is transformed to the suitable voltage and is transported by power cables to the grid.

### RUN OF THE RIVER SYSTEM

"Run of the river" systems do not require a dam or large storage facility. It simply diverts a part of the river flow and then sends it back to the river bed.

This makes run-of-the-river systems a low-cost way to produce power and avoids large environmental impact measures, unlike a dam.

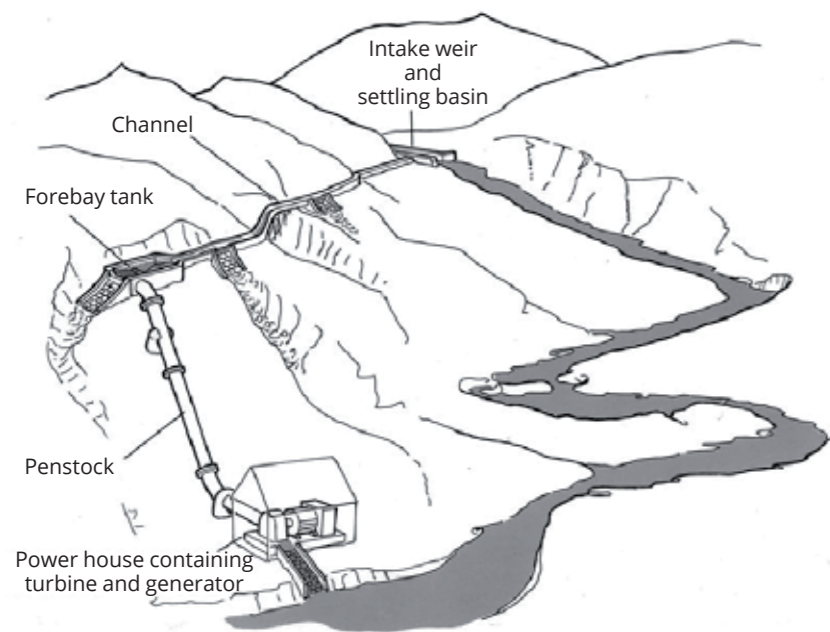

## COMPONENTS

### INTAKE & WEIR

The weir is a barrier across the river designed for pooling water behind it, to enable a controlled intake of water in the canal. In some cases, a part of the river flow, flows steadily over the top of the weir to ensure a minimum environmental flow in the natural river.

### CANAL, HEADRACE OR CHANNEL

The canal or headrace conducts the water from the intake to the forebay tank. Its length depends on the distance between the intake and the forebay, which are both chosen at an optimal location. This channel can be open or closed.

### FOREBAY TANK

The forebay tank is a pond-like structure at the top of the penstock, which regulates the fluctuations in the water flow. It forms the connection between the channel and the penstock. In the connection of the forebay with the penstock, a trash rack is installed to prevent large particles to enter the penstock.



### PENSTOCK

Through the penstock the water is dropped into the turbine. It is supported by concrete pillars and foundations, to resist the heavy forces of the water.



### POWER HOUSE

The powerhouse is the building that houses the turbine, the electric generator, a transformer and the control systems. Here the power cables leave towards the end consumer. From the powerhouse, the water flows back to the natural river bed.



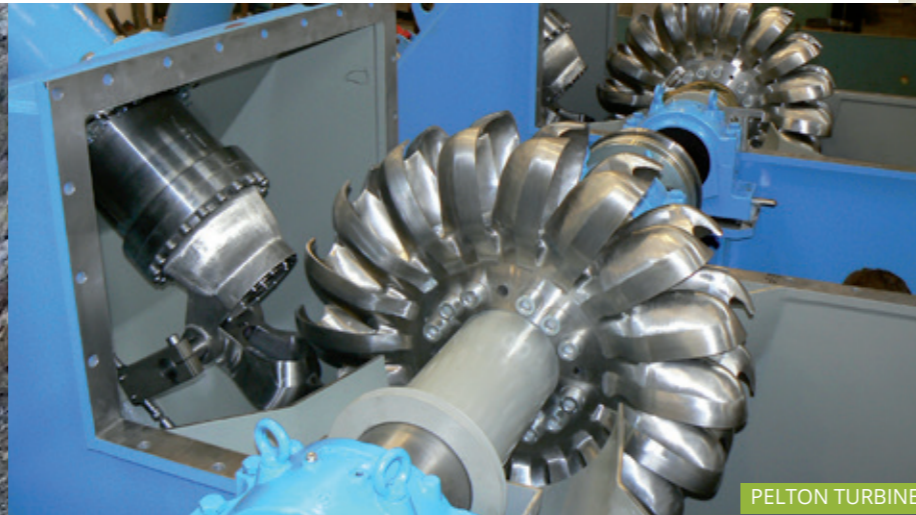

PELTON TURBINE

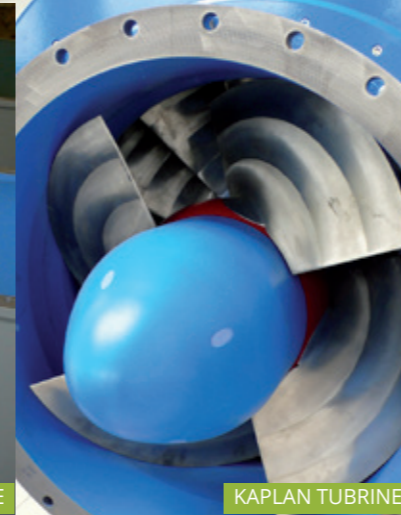

KAPLAN TURBINE

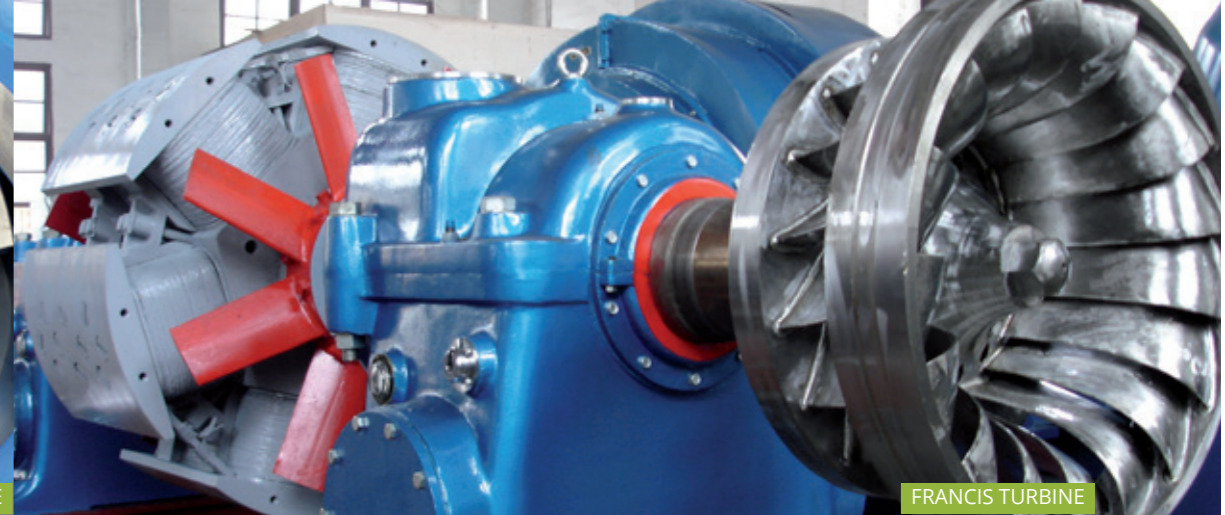

FRANCIS TURBINE

## OUTPUT

Hydro-turbines are efficient power converters with efficiencies in the range 80 – 95%. The overall efficiency depends on the electrical generator and transformation and ranges between 70 – 90%.



The electric output of a SHEPP is calculated as follows:

$$P_{el} = \text{head [m]} \times \text{flow [m}^3\text{/s]} \times \text{turbine efficiency} \times \text{generator efficiency} \times \text{transmission efficiency}$$

Upgrade Energy installs Francis turbines of 100 to 10 000 kWe.

## BENEFITS

### PROVEN TECHNOLOGY

- ✓ High reliability and availability,
- ✓ Almost no maintenance
- ✓ Operational lifetime, more than 30 years
- ✓ High efficiency

### ECONOMICAL

- ✓ Investment cost low compared to other small renewable energy technologies (Wind, Solar)
- ✓ Low operational & maintenance costs

### ENVIRONMENTALLY FRIENDLY

- ✓ Small hydro plants harmonize Optimally with nature and the landscape
- ✓ Negligible impact on local environments and ecosystems
- ✓ No harmful waste, no climate damaging emissions
- ✓ No consumption of valuable resources
- ✓ Fish-bypass possible

## APPLICATIONS

A hydroelectric facility requires a dependable flow of water and a reasonable head. Depending on these parameters, the optimal turbine type differs.

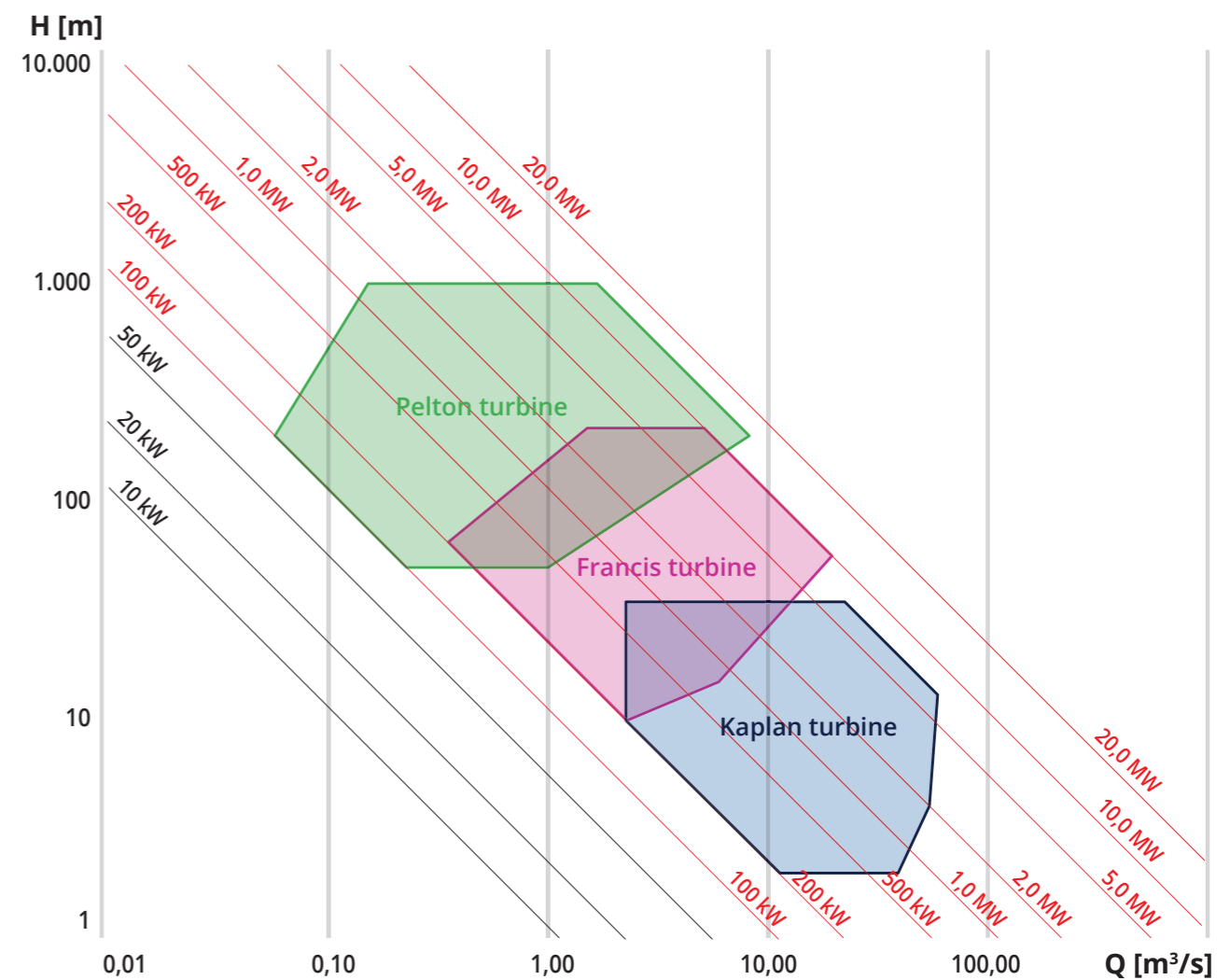

## REFERENCE CASE



Client	Government of the Philippines
River	Manicahan river
Type	Run-of-the-river
Head	150 m
Flow	2,1 m <sup>3</sup> /s
Capacity	2,5 MWe
Commissioning	2017
Payback period	6,8 years

## CONCLUSION

With a small hydro-electric power plant, a constant and secure amount of electricity is produced

It is a green, durable and low maintenance solution for generating electricity.

As part of a sustainable and environmentally friendly policy, the small hydro technology saves primary energy and decreases CO<sub>2</sub> emissions.

With small hydro, your organization or institution contributes to a greener future, in an economically viable way.







# WASTE TO ENERGY PLANT

RENEWABLE ENERGY  
FROM MUNICIPAL WASTE



## PROBLEMS WITH LANDFILLING

Currently, a lot of municipal waste is dumped on landfills, because there is no good application for the waste.

This landfilling however, causes considerable problems:

### 1 Surface emissions

Possibly the biggest health and environmental concerns are related to the uncontrolled surface emissions of LFG into the air. LFG contains carbon dioxide, methane, volatile organic compounds (VOCs), hazardous air pollutants (HAPs), and odorous compounds that can adversely affect public health and the environment. Carbon dioxide and methane are greenhouse gases that contribute to global climate change. Methane is of particular concern because it is 25 times more effective at trapping heat in the atmosphere than carbon dioxide. Emissions of volatile organic compounds contribute to ground-level ozone formation (smog). Ozone reduces and damages vegetation growth and causes respiratory problems. Exposure to hazardous air pollutants causes a variety of health problems, such as cancer, respiratory irritation, and central nervous system damage.

### 2 Subsurface migration

Subsurface migration is the underground movement of landfill gas (LFG) from landfills to other areas within the landfill property or outside the landfill property. Since LFG contains approxima-

tely 50% methane, it is possible for LFG to travel underground, accumulate in enclosed structures, and ignite. Incidences of subsurface migration have caused fires and explosions on both landfill property and private property.



### 3 Space

The space taken in by landfills cannot be used for other economical, recreational or other activities.

### 4 Odors

The final concern related to uncontrolled LFG emissions is their unpleasant odor. Compounds found in LFG are associated with strong, pungent odors. These smells are transmitted off site to nearby communities.

## SOLUTION

### POWER GENERATION FROM MUNICIPAL WASTE

Upgrade Energy offers a clean and economically viable solution for the disposal of landfill waste and the simultaneous generation of renewable energy. The produced electricity is consumed by the same community that provides the waste.



Upgrade Energy designs, installs and maintains waste to energy plants of 200 kWe to 20 MWe.

### HOW IT WORKS

The municipal waste is burnt in a furnace. The heat from this furnace is used for steam generation, which drives a steam turbine. The steam turbine is coupled to a generator, which produces electricity. After expansion of the steam over the steam turbine, the condensate is sent back to the furnace to resume the cycle.

The exhaust gasses are cleaned before they are emitted into the atmosphere. The ash generated by the furnace is collected and disposed of.

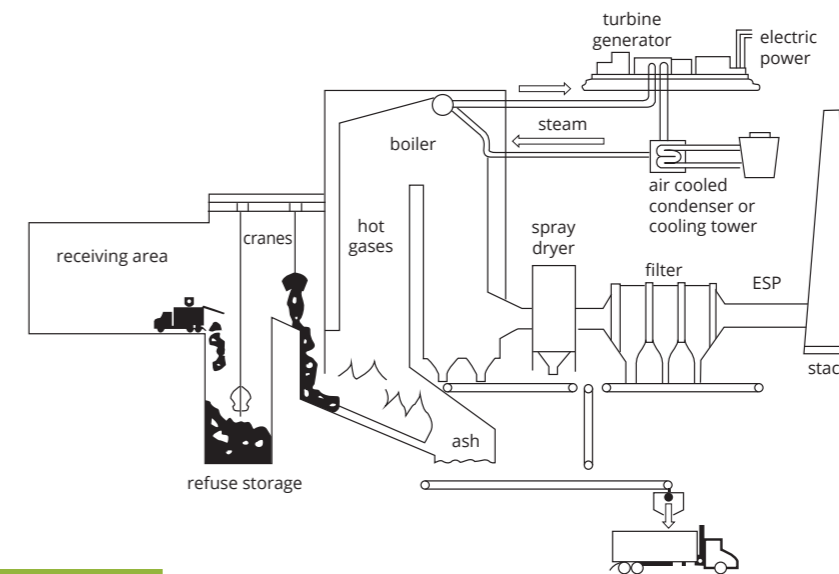

### BENEFITS

- ✓ Recovery of energy in the waste, instead of buying energy
- ✓ Own electricity generation -> more independence
- ✓ Clean disposal of waste
- ✓ Addressing climate mitigation and other environmental goals in a cost-effective way
- ✓ Sustainable development

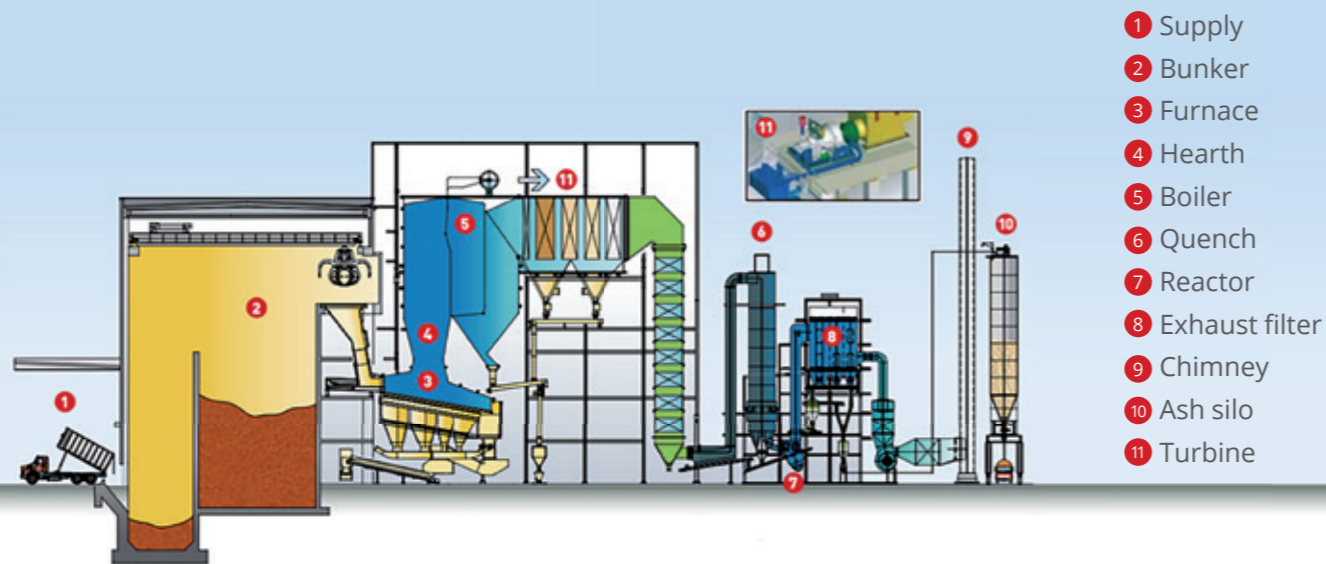

## PLANT COMPONENTS

### SUPPLY

The plant produces green energy from residual waste coming from pre-treated and sorted industrial and municipal waste. The pre-treatment includes the removal of non-combustible components (such as metal and stone), and a systematic crushing to small parts which enhances the combustibility and drying of the waste.

### THE BUNKER

In the bunker, the fuel for the waste to energy plant is collected. An automatic crane brings the waste into the funnel of the furnace. When the crane is not used for filling the furnace, it is used for mixing the waste in the bunker.

### THE COMBUSTION GRATE

The waste comes out of the funnel onto the grid. This grid consists of stairs/stages that move relative to each other in order to make the fuel slowly advance through the furnace. At the end of the grate, the waste is completely burned out. The remaining ashes are collected.

Due to the high temperature in the oven, the waste ignites spontaneously, so no extra fuel is necessary. The temperature of the fuel on the grate goes up to 250 °C. Therefore, the stairs are cooled by a closed water circuit.



### BOILER

In the boiler, water is converted into steam, using the heat generated in the furnace. The boiler wall is composed of water tubes. These are heated by the several meter high flames in the boiler.

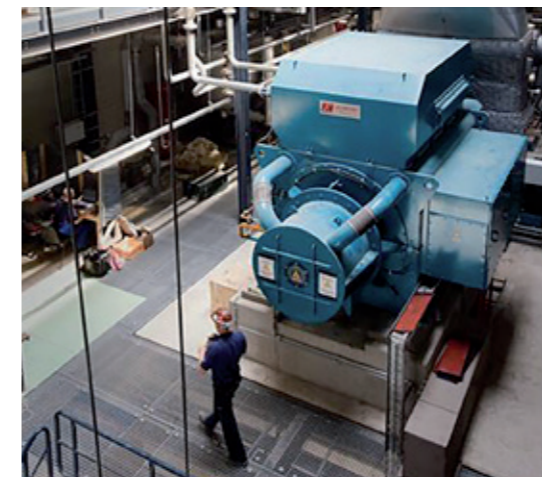

### TURBINE AND GENERATOR

The generated steam flow meets the turbine blades. Because of the high pressure steam impact, the turbine starts rotating and drives the electric generator. The electricity produced by the generator is transformed and injected into the grid.



### CONDENSER

The expanded steam leaving the turbine is converted back to water in the condenser, using the cooling effect of the ambient air.

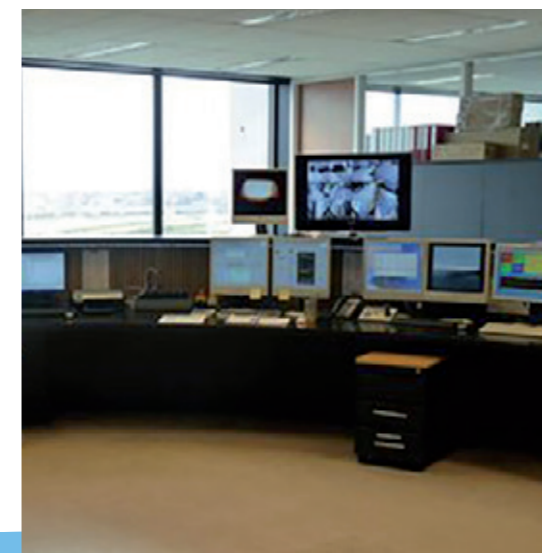

### CONTROL ROOM

The waste to energy plant is fully controlled from the control room. Here, all components (measuring devices, valves, motors ...) are connected with a central control system and all measurements (temperature, level, pressure, flow) are visualized.

## HEARTH

The after-treatment of the exhaust gases starts already in the hearth: urea is added in order to reduce the nitrogen oxides (NOx).

## QUENCH AND REACTOR

In the quench, the flue gases are cooled and mixed with lime in order to bind the acidic particles in the exhaust.

In the reactor, activated lignite is injected, which reacts with the dioxins, furans, and heavy metals in the flue gas.

## FILTERS

The filter extracts the harmful particles (which are tied to the lime and activated lignite) from the flue gases. The fly ash is collected by the bag filters. The separated material is then collected in the ash silo.

After intensive cleaning, the flue gases leave the installation via the chimney.

The emissions are measured and monitored through both continuous and periodic measurement and sampling.



## POLLUTION CONTROL

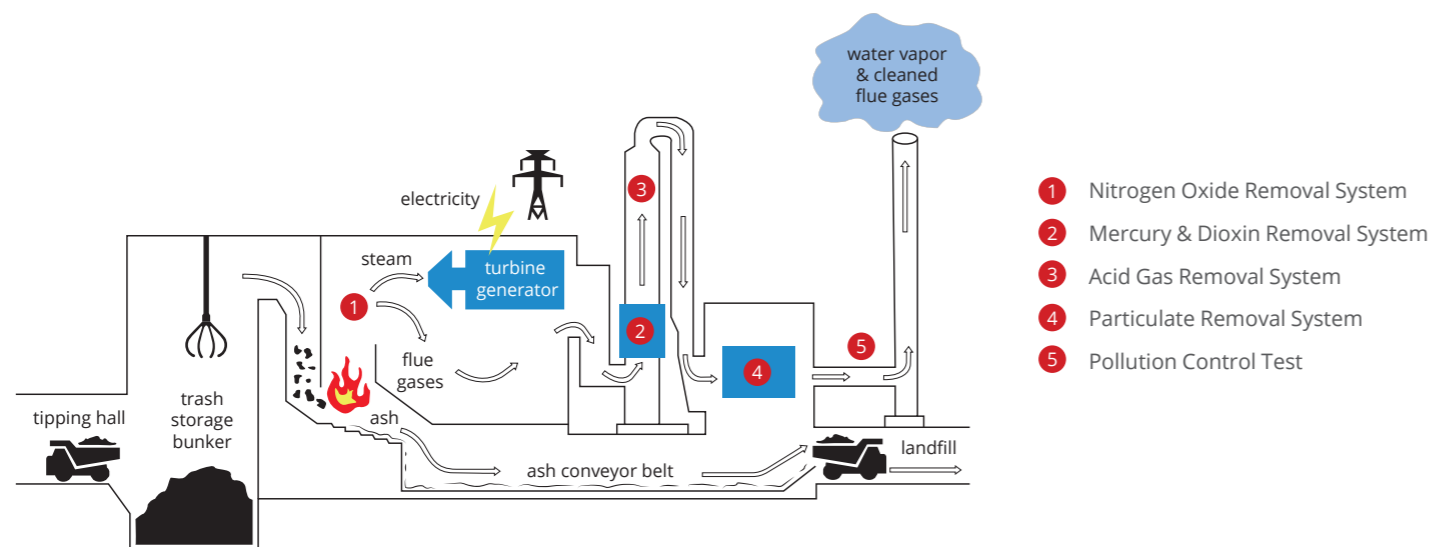

## REFERENCE CASE

Client	Biosteam (Belgium)
Capacity	18 MW
Waste disposal rate	160 800 tons / year
Operation	49 weeks / year
Commissioning	2009



1,3% of the produced electricity is lost, 9,3% is consumed by the plant itself and 89,4% is injected into the electricity grid.

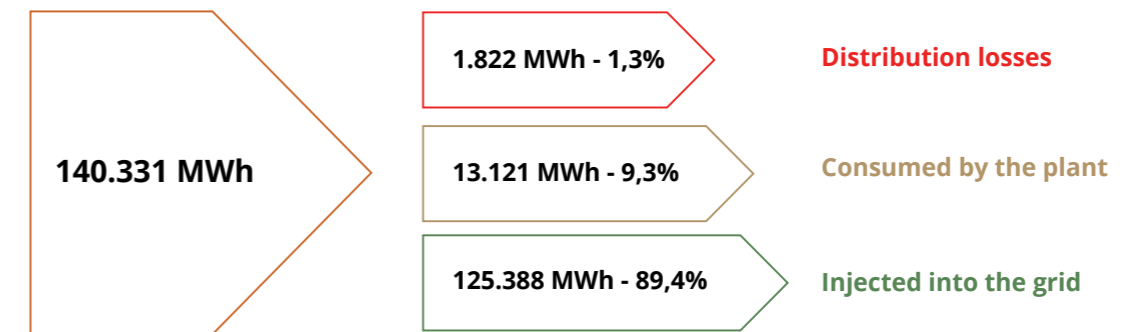

## CONCLUSION

The energy in your municipal waste is transformed into a predictable and constant amount of useful and valuable electricity.

It is a sustainable, green and cost-effective way to supply your city or municipality of power.

As part of a sustainable and environmentally friendly policy, the waste to power technology contributes to significant reduction of primary energy consumption and tackles landfill problems.

With the waste to energy plant, your community changes from being an energy consumer, to an energy producer and contributes to a greener future.





# BIOMASS DIGESTION

HEAT AND POWER  
FROM BIOLOGICAL WASTE



## BIOGAS PRODUCTION

### BIOMASS DIGESTION

During the anaerobic digestion (or fermentation) process, biomass (manure, food waste, waste from the agro-industry, ect.) is degraded in the absence of oxygen ("anaerobic"), by a large population of microorganisms. Biogas and digestate are produced. The biogas is used as a combustion gas and the digestate is used as fertilizer.

The fermentation process is a delicate balancing act. The optimal conditions for this process are at a pH of 7 and a temperature of +/- 35 °C - 37°C (mesophilic process) or 55 ° C (thermophilic process).

The main components in biogas are: methane, carbon dioxide, water and small amounts of hydrogen sulphide and ammonia.

PROPERTIES	UNIT	BIOGAS FROM ANAEROBIC DIGESTION	NATURAL GAS (CNG)
Calorific value (LHV)	MJ/Nm <sup>3</sup>	19,7 - 23,3	31,7
Density	kg/Nm <sup>3</sup>	ca. 1,21	ca. 0,82
Methane (CH <sub>4</sub> )	%	50 - 75	ca 82
Carbon dioxide (CO <sub>2</sub> )	%	25 - 50	0 - 2
Hydrogen sulphide (H <sub>2</sub> S)	mg/Nm <sup>3</sup>	100 - 1000	0,8
Ammonia (NH <sub>3</sub> )	mg/Nm <sup>3</sup>	0 - 100	3
Siloxanes	mg/Nm <sup>3</sup>	0 - 50	0
Chlorine containing compounds	mg/Nm <sup>3</sup>	0 - 100	50
Fluorine-containing compounds	mg/Nm <sup>3</sup>	0 - 100	25



## COMBINED HEAT AND POWER PRODUCTION

### BIOGAS YIELD

depends on:

- Dry and organic matter content;
- Freshness of the product in connection with for fermentation;
- The degradability of the organic material;
- The residence time in the digester

### WHAT IS CHP?

A combined heat and power (CHP) installation is a power plant that produces heat and electricity by burning fuel.



ELECTRICITY

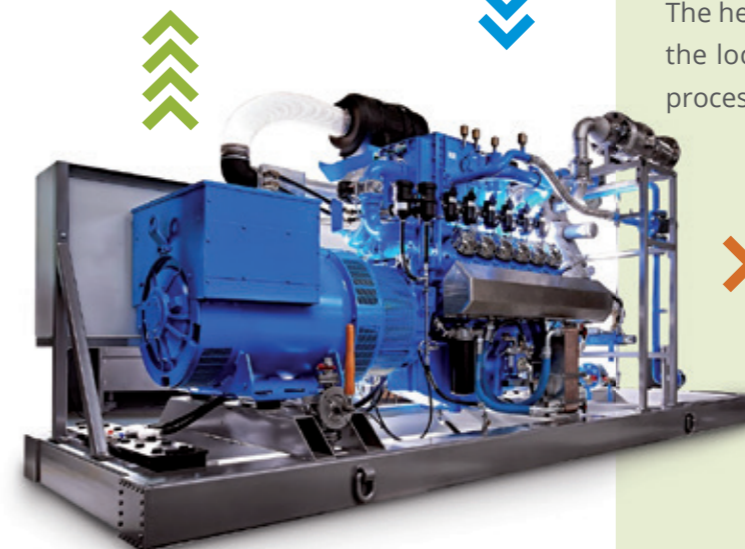

FUEL

HEAT

Upgrade Energy's CHP units consist of a gas engine, coupled to a generator. The motor runs on natural gas, syngas or other fuels and drives the generator, which produces electricity.

The heat produced by the engine is utilized in the local process (e.g. water heating, drying processes, thermal oil heating).

## PURPOSE

The purpose of a CHP installation is to save primary energy. Heat and electricity are generated simultaneously and on the same location, through the combustion of fuel. The efficiency of this energy generation is much higher than buying electricity from the grid and generating heat separately. Transport and distribution losses are avoided and waste heat from electricity generation is applied in a useful way. With a classic electricity production the produced heat is blown off into the atmosphere.

CHP technology reduces primary energy consumption up to 50%.

Moreover, 1 kWh of gas is cheaper than 1 kWh electricity, which makes CHP technology reduce your overall energy costs.

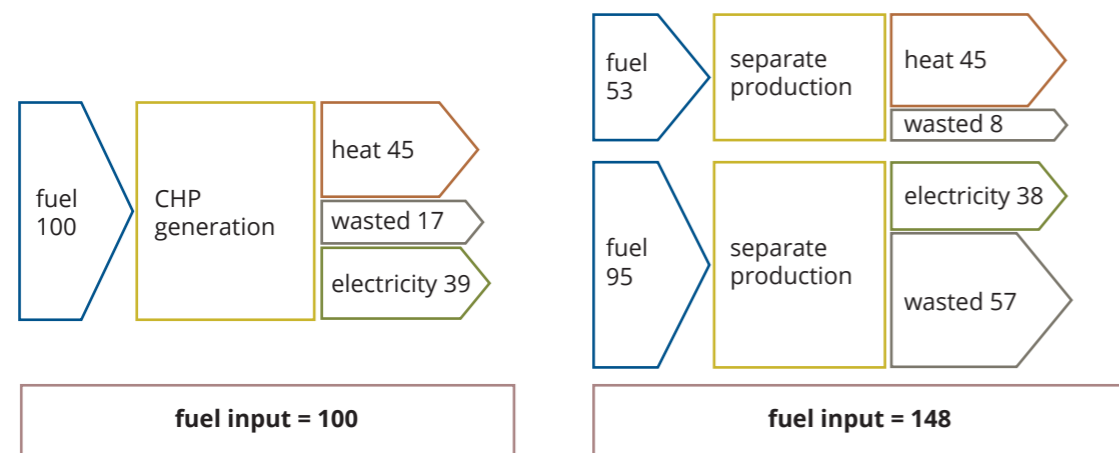

## BENEFITS

- ✓ Big savings on electricity costs by own generation
- ✓ More independence from the volatile energy market
- ✓ Optimal usage of fuel
- ✓ Saving primary energy, reducing CO<sub>2</sub> impact.
- ✓ Existing systems can remain as back-up
- ✓ Long lifespan: 60 000 operating hours, when subjected to big revision, 120 000 operating hours.



**BIOGAS FUELED CHP PLANT**

By fermentation of biomass, biogas is produced, which is used as fuel for a cogeneration (CHP) unit. The energy in the organic material is thus converted into heat and electricity.

The generated heat is partly used to maintain the digester at the right temperature. The rest of the heat is used for heating buildings, circuits, products, tanks or in the local production process (drying, preheating). The electricity is used entirely by the factory or partially sold to the grid.

The heart of the system is the digester tank, where the anaerobic fermentation takes place. A dosage system is provided to continuously provide the right amount of fresh biomass to the digester.

The mixture in the digester, the substrate, is maintained at the

desired temperature, through a heat exchanger. A mixing system is installed to avoid layer formation and ensures a good contact between the biomass and the bacteria.

The reactor is covered with a membrane, under which the biogas is collected. The produced biogas is used to drive the CHP engine.

After digestion of the biomass, the now pumpable material is pumped directly into the digestate tank. Here the digestate is stored, optionally with 'after digestion', before it is used as a fertilizer.

To protect the CHP engine against wear, the biogas is desulphurised and dewatered, before entering the engine.

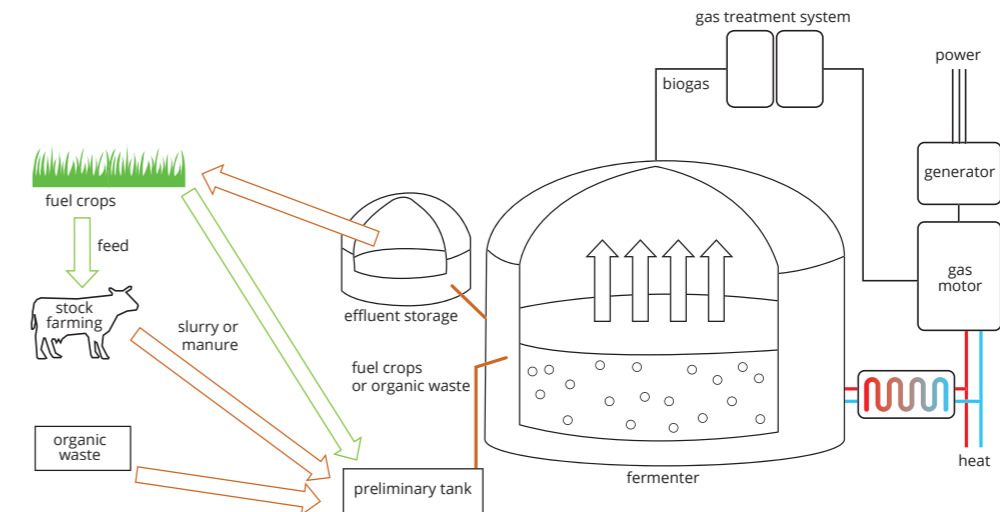

## BENEFITS

- ✓ Because bio-fermentation uses only organic material as input, it produces a sustainable and CO<sub>2</sub>-neutral fuel.
- ✓ Environmentally friendly disposal of biological waste, dung and residues
- ✓ Independent of weather conditions (unlike solar and wind energy)

## APPLICATIONS

A biogas CHP installation is interesting for any company that has waste water or organic waste with organic compounds:

- Silage
- Animal farms
- Agro industry
- Food processing
- Beverage production
- Water treatment

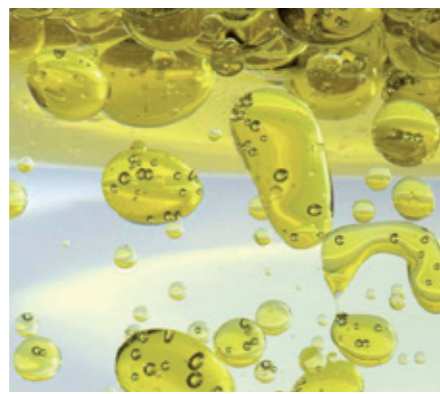

## FIGURES

The average methane yield of anaerobic fermentation is approximately 37 Nm<sup>3</sup>/ton treated biomass. This yield, however, can vary from 20 Nm<sup>3</sup>, for the fermentation of pure manure, to 600 m<sup>3</sup>, for the fermentation of mixtures with very high degradable organic material content, such as rape seed cake and fats.

The energy content of methane is 9,94 kWh/Nm<sup>3</sup>. Meaning that per ton biomass, an average of 37 m<sup>3</sup> of methane is produced and thus generates 368 kWh of bio-energy.

These 368 kWh are then converted by the CHP into about 140 kWh of electricity and 190 kWh of heat.

## Biomethane Potential From Organic Residuals

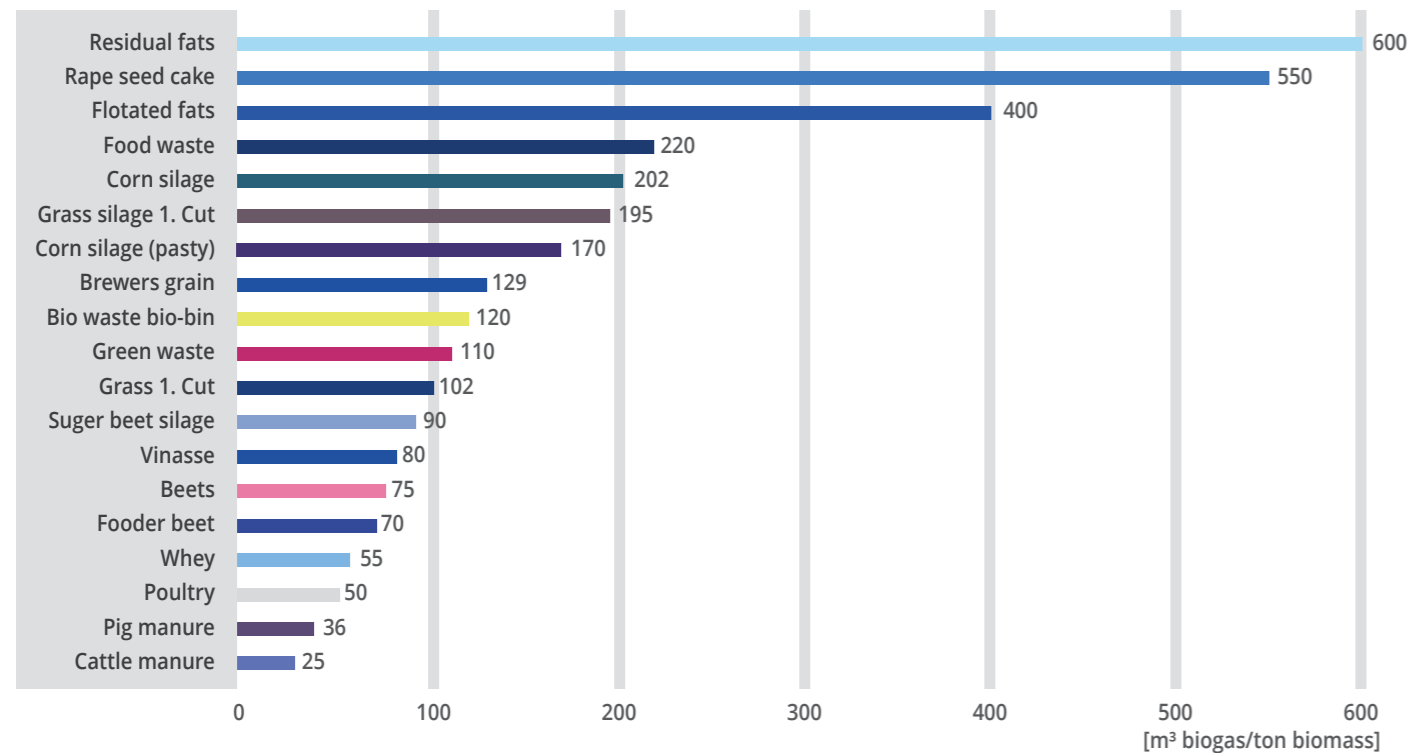

## REFERENCES

Client	Dries Energy (Belgium)
Industry type	Agriculture
Technology	Anaerobic digestion
Electric output	1,2 MWel for grid injection
Heat output	1,4 MWth for drying of the digestate, hygenisation and heating the fermenter
Fuel	Biogas (CH <sub>4</sub> + CO <sub>2</sub> )
Commissioning	2013



Client	Clean Energy Ternat (Belgium)
Industry type	Agriculture
Technology	Anaerobic digestion
Electric output	400 kWel for the farm and grid injection
Heat output	480 kWth for drying of the digestate, hygenisation and heating the fermenter
Fuel	Biogas (CH <sub>4</sub> + CO <sub>2</sub> )
Commissioning	2015



## CONCLUSION

A biogas CHP installation

- Disposes of organic waste
  - Produces heat and electricity
  - Produces good fertilizer for crops
- And saves money in 2 different ways:
- By own (cheaper) generation of electricity from waste products
  - By using the free excess heat instead of buying fuel

For every ton of biomass the installation consumes, more valuable electricity and heat is generated. As part of a sustainable and environmentally friendly policy, the biogas powered CHP technology saves primary energy and decreases your company's CO<sub>2</sub> emissions.

With biomass powered CHP technology your business contributes to a greener future, in an economically viable way.

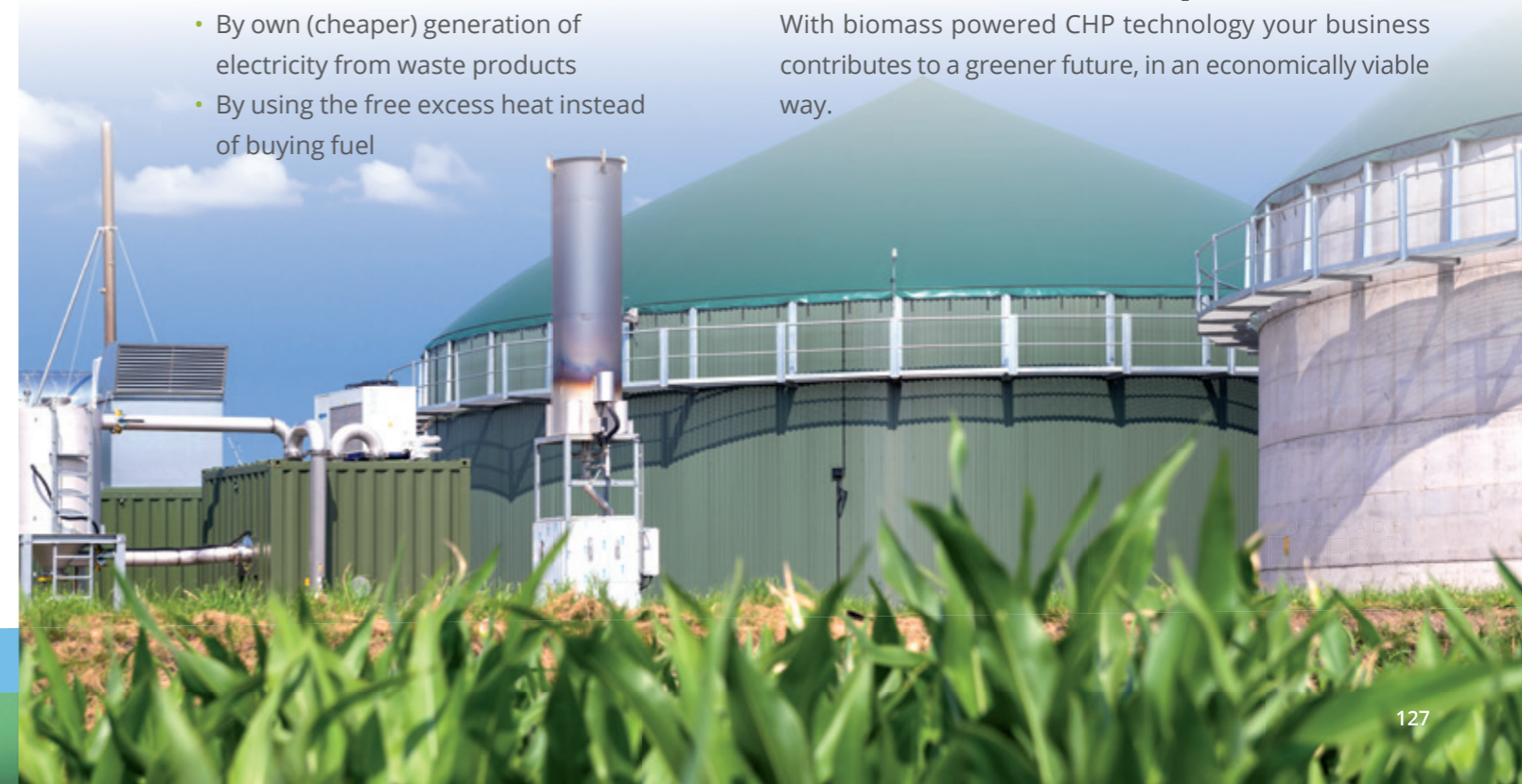





# GASIFICATION POWER PLANT

HEAT AND POWER FROM  
WOOD-LIKE FUELS

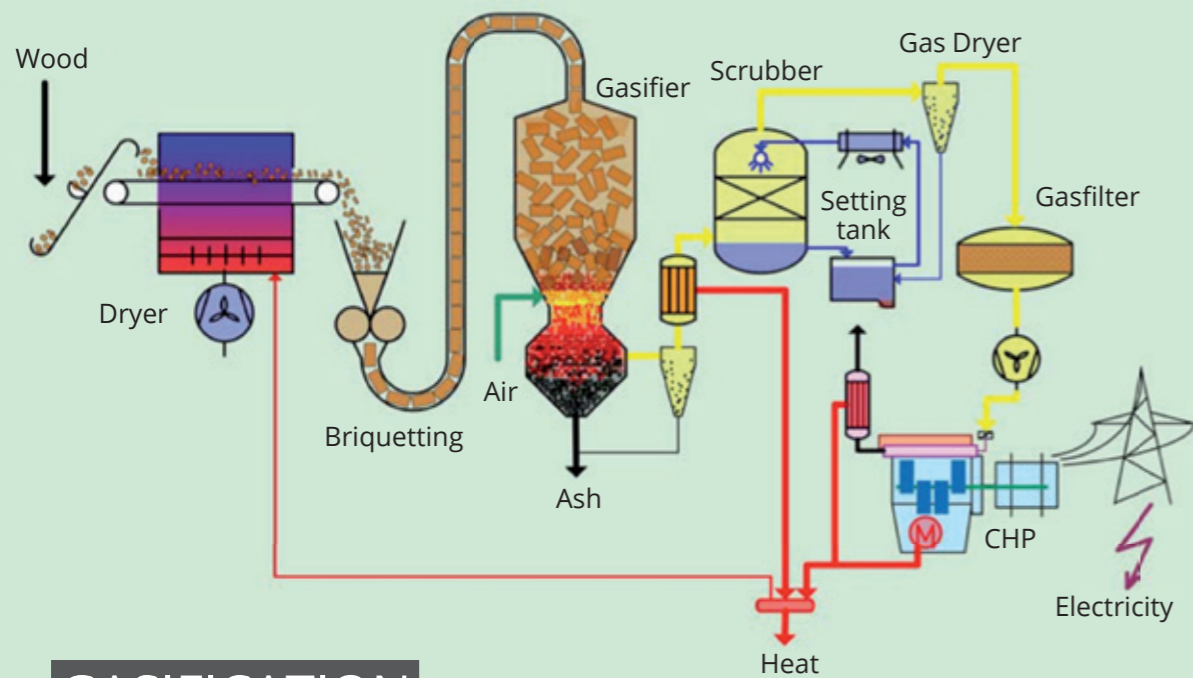

## GASIFICATION

### WHAT IS GASIFICATION?

Gasification is the process that converts the energy from organic, wood-like materials into a combustible gas. This is achieved by reacting the material at high temperatures, without combusting it, using a controlled oxygen inlet. The resulting gas mixture is called syngas.

Syngas can be burned directly in CHP gas engines for the simultaneous production of heat and electricity (combined heat and power or CHP principle). Like other gaseous fuels, syngas gives greater control over power levels when compared to solid fuels, leading to more efficient and cleaner power generation.

### WORKING PRINCIPLE

A gasification plant consists of two main processes:

- The production of clean gas
- Combusting the gas in a CHP engine to produce heat and electricity

The purpose of the plant is to cover the heat and electricity demand of a factory, using biomass as a fuel.

### Fuel to syngas

The gasification process is appropriate for the energetic utilization of wood-like fuels, such as wood, wood scrap, shells, husk, hulls and pellets. The fuel is first prepared (shredded, dried and briquetted if necessary) and then gasified during a single-step process. The product gas is washed and filtered for clean combustion in the engine.

### Heat and power generation

The CHP engine shaft drives a generator for electric power production.

The waste heat from the motor bloc and exhaust gas is partially used for drying the biomass and partially for the use in the factory's heating processes, such as heating thermal oil, drying purposes, preheating water for steam production, etc.

### Gasification process

The gasification process itself is divided in 4 zones. The carbonaceous material undergoes several different processes.

The ashes formed by the process are used as quality fertilizer.

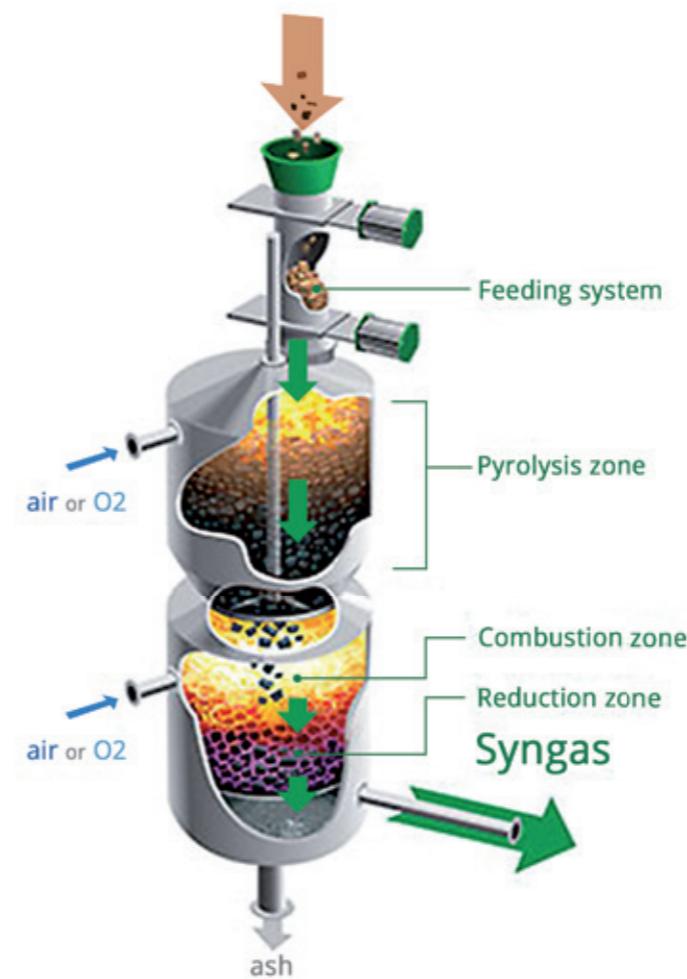

### 1 The drying zone

In the drying zone, the free, chemically not bound, water evaporates at approximately 200 °C. It is condensed and drained by special condensate traps. The condensate is sprayed over the dryer silo, evaporates and is removed with the exhaust air. The other part of the water vapor is converted in the following zones.

### 2 The carbonization zone

Here the pyrolysis takes place. The chemically bound water and other distillates are driven out, while the wood-like fuel is converted at high temperatures to charcoal and a carbonization gas. This gas consists mainly of long chained hydrocarbons and CO<sub>2</sub>.

### 3 The combustion zone

Tars and other distillates are gasified at the dominant temperatures of approximately 1200°C. The appropriate amount of air is supplied by means of a nozzle ring.

The nozzles are supplied with air by spiral pipes, surrounded by the hot raw gas, to make sure the air is preheated.

The following essential reactions take place: C and O<sub>2</sub> react to CO<sub>2</sub> and CO. H<sub>2</sub> and O<sub>2</sub> react to water vapor. Carbonization gas, from higher hydrocarbons (formed in the carbonization zone) is split up ("cracked").

### 4 The reduction zone

C and CO<sub>2</sub> react to CO. Carbon and water vapor react to CO and H<sub>2</sub>. C and H<sub>2</sub> react to CH<sub>4</sub> (methane).



## APPLICATIONS

### BENEFITS

- ✓ Conversion of organic waste into renewable fuel
- ✓ Modular design
- ✓ More independence from the volatile energy market
- ✓ Independence of weather conditions (unlike solar and wind power)
- ✓ CO<sub>2</sub> neutral technology
- ✓ Free quality fertilizer as by-product

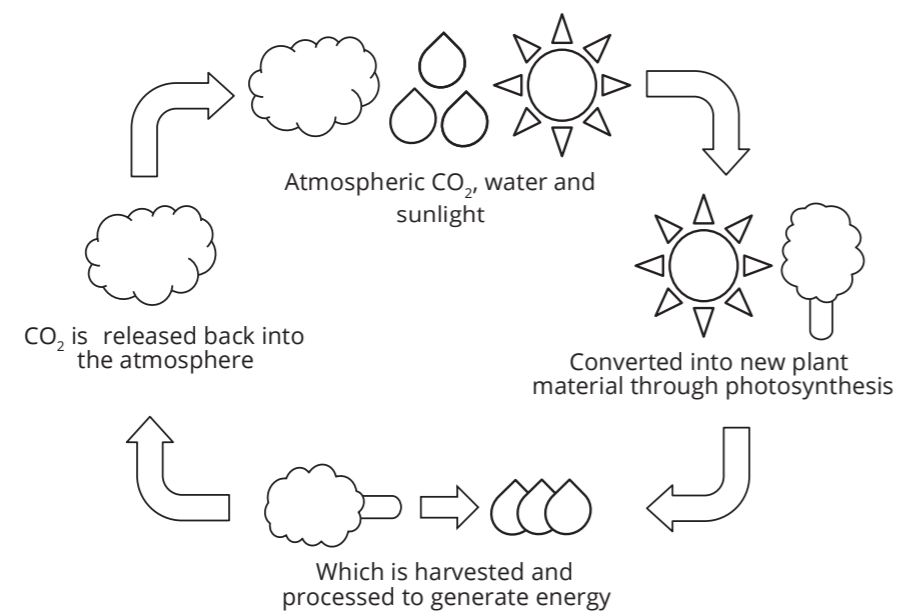

Gasification can be applied for all kinds of wood-like fuels.

Industries:

- Nuts
- Eucalyptus
- Bark
- Forest management
- Husk
- Hulls
- Pellets
- Shells

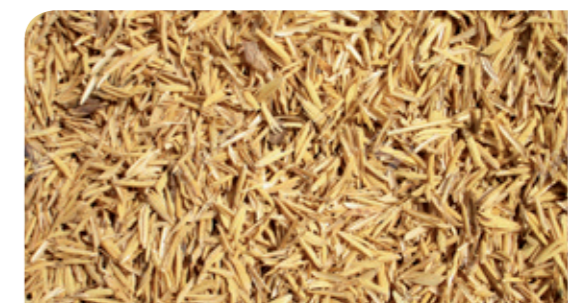

## REFERENCE

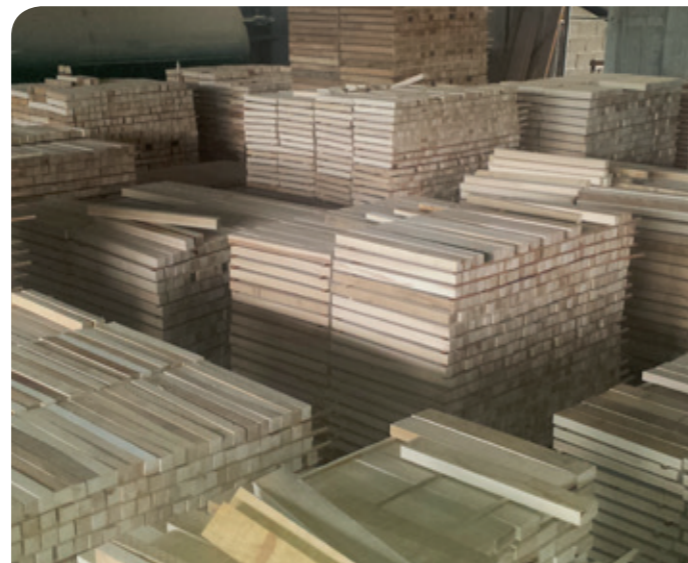

Client	Whitefield, Croatia
Industry type	Wood processing
Biomass source	Wood scrap
Capacity	4 x 250 kWe
Commissioning	2016

## CONCLUSION

Upgrade Energy's gasification plant produces a constant and secure amount of electricity and heat and disposes of your biological waste. It is a green, durable, cost-effective and reliable answer to your heat and electricity demand.

As part of a sustainable and environmentally friendly policy, the gasification technology saves primary energy and decreases your company's CO<sub>2</sub> footprint.

With gasification technology, your business contributes to a greener future, in an economically viable way.





## HEAT AND POWER FROM BIOMASS COMBUSTION



## HEAT AND POWER FROM BIOMASS COMBUSTION

Upgrade Energy transforms waste products into heat and power, using a biomass fueled boiler and a steam turbine.

The biological waste is burned in the boiler in order to generate heat. The combustion heat converts water into steam. The steam is then expanded in a steam turbine which is connected to an electric generator. This way electricity is produced from biomass.

The expanded steam is condensed in a condenser and is finally led back to the boiler, in order to resume the cycle.

The excess heat coming from the condenser is used

- In the production process
- For drying the biomass (before burning)

The remaining ashes are used as fertilizer in plantations.

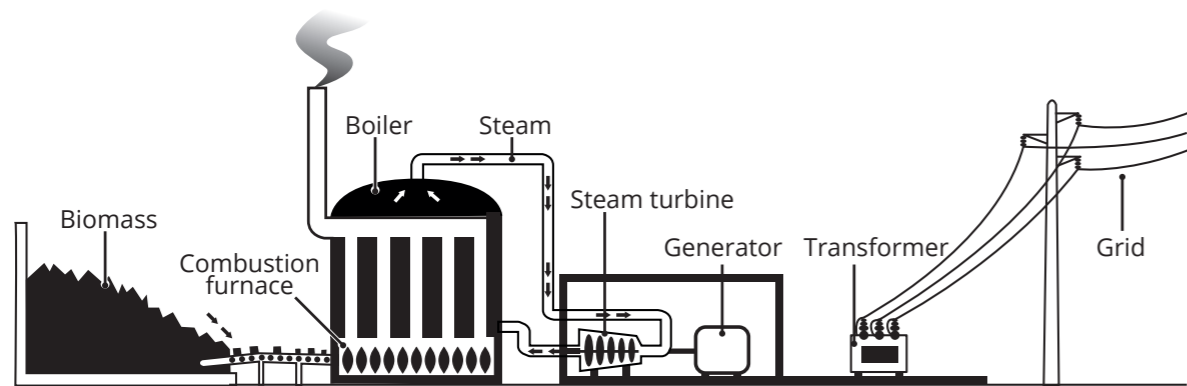

### BENEFITS

- ✓ Usage of organic waste as renewable, sustainable and CO<sub>2</sub>-neutral fuel
- ✓ Saving through own (cheaper) energy generation
- ✓ Environmentally friendly disposal of biological waste
- ✓ Quality fertilizer by-product
- ✓ Independence of weather conditions (unlike solar and wind energy)
- ✓ More independence of the volatile energy market

## APPLICATIONS

### INDUSTRIES:

- Energy crops
- Wood
- Food residues: straw, husk, hulls, shells, empty fruit bunches
- Poultry litter

Upgrade Energy designs, installs and maintains biomass combustion CHP plants from 100 kWe – 5000 kWe.



## CONCLUSION

The utilization of biological resources is strategically viable as it contributes to the sustainability of energy supply, while minimizing the negative impacts of energy generation on the environment.

The use of biomass as a source of energy is one of the most cost effective ways of using residues.

A biomass combustion installation

- Disposes of organic waste
- Produces electricity (and heat if required)
- Produces a good fertilizer

And saves money in 2 different ways:

- By own (cheaper) generation of electricity (and heat if required)
- By using a almost free energy source instead of buying fuel

# TRACK RECORD UPGRADE ENERGY

## EUROPE

### BELGIUM

#### Constructed projects



DRIES ENERGY

- Zur Morsheck 10, 4770 Möderscheid/Amel, Belgium
- Agriculture and food industry
- Biogas (biomass digestion + CHP)
- 600 kWe
- 31 October 2012



BELGIAN FIBRES MANUFACTURING

- Industriëlaan 91, B-7700 Moeskroen, Belgium
- Synthetic fibers industry
- Trigeneration
- 1200 kW electricity/200 kW cooling
- 2016
- <http://www.belgianfibers.com>

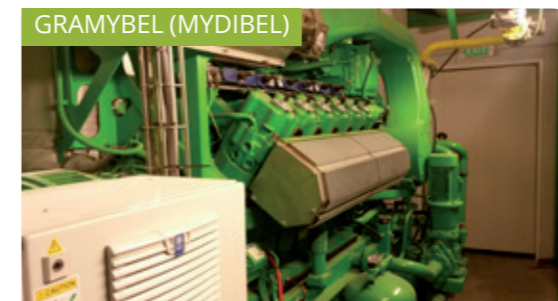

GRAMYBEL (MYDIBEL)

- Boulevard de l'Eurozone, 1, Mouscron 7700, Belgium
- Food industry: potato processing
- Biogas and natural gas CHP + solar PV
- 800 kWe (CHP) + 2000 kWp (solar)
- 8 September 2015
- <https://www.mydibel.be/en>



CAPSUGEL

- Rijksweg 11, B-2880 Bornem, Belgium
- Pharmaceutical industry
- Natural gas CHP
- 1200 kWe (CHP)
- 10 January 2015
- <https://www.capsugel.com>





GOURMAND

- Drève Gustave Fache 6, Mouscron 7700, Belgium
- Industrial bakery
- CHP + solar energy
- 515 kWe + 500 kWth (CHP) + 238 kWp (solar)
- 2017
- <https://www.gourmand.eu>



ARGEX

- Kruibeksesteenweg 162, 2070 Burcht, Belgium
- Construction materials
- ORC
- 3 x 125 kWe
- 2015
- <https://www.argex.eu>



DECEUNINCK

- Bruggesteinweg 360, 8830 Hooglede, Belgium
- Extrusion industry
- Relighting + PV smart flower
- 105 led armatures
- 2016
- <http://www.deceuninck.be>



CLEAN ENERGY TERNAT

- Pangaardenstraat 2, Ternat, Belgium
- Agriculture and food industry
- Biogas (biomass digestion + CHP)
- 400 kWel
- 1 April 2016



XPO LOGISTICS

- Rue de l'Industrie 14, Welkenraedt, Belgium
- Logistics of chemicals
- Natural gas CHP + heat pump + solar
- 350 kWel + 200 kWth + 240 kWp
- 2017
- <https://www.xpo.com>



AZ SINT BLASIUS

- Kroonveldlaan 50, 9200 Dendermonde, Belgium
- Hospital
- Natural gas CHP
- 600 kWe (CHP)
- 2013
- <http://www.azsintblasius.be>



SAPA

- Ghlin, Belgium
- Aluminum profiles
- Solar energy
- 750 kWp
- 2017
- <https://www.sapabuildingsystem.com/en>



BOORTMALT

- Chaussée de Charleroi 40, 5030 Gembloux, Belgium
- Natural gas CHP + PV
- 260 kWe (CHP) + 250 kWp (solar)
- June 2018
- <http://www.boortmalt.com>



Q-FOOD

- Rue Fernand Tilquin, 6464 Baileux (Chimay), Belgium
- Solar Energy
- 250 + 150 kWp
- 25 January 2018
- <http://q-food.be>



GENT ASSET ONE

- Deinsteenweg 114, 9031 Drogen, Belgium
- Office buildings
- Relighting + solar energy + EV charging point
- 48 kWp + 246 led panels, 47 led spots, 48 downlights, 36 led tubes
- 2016



STOCKHABO AND STOCKHABO ICE

- Avenue Nadine Pollet-Sengier 12, 7700 Mouscron, Belgium
- Warehouses and cold storage
- Solar energy
- 998 +250 kWp
- 2016
- <http://www.stockhabo.be>



VAN MOER LOGISTICS

- Hazopweg – Haven 1167, 9130 Kallo, Belgium
- Logistics warehouses
- Relighting
- 54 kW
- October 2016
- <https://vanmoer.com>



LOTUS BAKERIES

- Lembeke + Courcelles + Oostakker, Belgium
- Industrial bakeries
- Solar energy
- 150 + 150 + 250 kWp
- 2016
- <https://www.lotusbakeries.com>

And many more photovoltaic installations...

### Under construction



ASHLAND SPECIALITIES BELGIUM

- Geslecht 2, 9130 Doel, Belgium
- CHP
- 2 MWe
- 2018
- <https://ashlandspecialitiesbelgium.jimdo.com>



UPGRADE BIO ENERGY

- Sint-Antoniusweg 1700, 9120 Kallo, Belgium
- Agriculture and food industry
- Biogas (biomass digestion + CHP)
- 3 MWe
- Rebuild in 2018

## TURKEY

### Constructed projects



WINSA

- Suadiye Yolu No:1, Kartepe/Kocaeli (İzmir), Turkey
- Extrusion industry
- Trigenation + PV
- January 2017 > 1560 kWe/1580 kWc
- 2014 > 650 kWp
- <https://www.winsa.com.tr>



EFE SERSA PROJECT

- Gaziantep, Turkey
- Solar Energy
- 1085,76 kWp
- 2017



TEKNOPANEL

- MTOSB 7.Cad. No:10 PK:33443 Huzurkent, Turkey
- Solar Energy
- 1700 kWp
- 11 November 2016
- <https://www.teknopanel.com.tr>



FRONTO

- Turkey
- Solar Energy
- 1000 kWp
- 2017



TEKNOISOLAYSION GES

- Turkey
- Solar Energy
- 385,7 kWp
- 2017

#### EGEPEN DECEUNINCK



- Turkey
- Extrusion industry
- Relighting
- 216 x 200 W high bays + 51 led tubes
- 2016
- <http://www.egepen.com.tr/en>

#### BIMAS GES



- Turkey
- Solar Energy
- 323 kWp
- 2015

#### BOSKIR GES



- Turkey
- Solar Energy
- 488,9 kWp
- 2017

#### MEGAVAT ENERJI



- Turkey
- Solar Energy
- 372 kWp
- 2017

#### BRIZA



- Turkey
- Solar Energy
- 1000 kWp
- 2018

#### Under construction

#### EGEPEN DECEUNINCK

Coming soon

- Turkey
- Extrusion industry (Window profiles and hardware)
- Natural gas CHP engine
- 4.3 MWe
- 2018
- <http://www.egepen.com.tr/en>

## CROATIA

### Constructed projects

#### WHITEFIELD ENERGY D.O.O. (PERGAMENT)



- Bjeloplje 65, 53230 Korenica, Croatia
- Wood processing industry
- Wood gasification (biomass)
- 1 MWeI + 1070 kWth
- 2017
- <http://www.pergament.hr>

#### ORIOOLICK D.D.



- 35250 Oriovac, Zagrebačka 37, Croatia
- Furniture industry
- Solar energy
- 330 kWp
- 31 October 2014
- <http://www.oriolik.hr>

#### ČATEKS D.D.,



- Zrinsko-Frankopanska 25, 40000 Čakovec, Croatia
- Fabrics industry
- Solar Energy
- 330 kWp
- 15 April 2015
- <http://www.cateks.hr>

## BOSNIA & HERZEGOVINA

### Constructed projects

#### PODVIC HPP



- Bosnia and Herzegovina
- Hydro-electric power plant
- 1 MWeI
- 2018

#### SOLAR ENERGY D.O.O.



- Caplijna, BiH
- Solar energy
- 1000 kWp

## LITHUANIA

### Constructed projects

#### UPGRADE INVEST



- Klykoliu str. 29 – Naujoji – Akmenė, Lithuania
- Solar Energy
- Ground mounted 9 X 30 kWp
- 4 April 2013

## ASIA

## CAMBODIA

### Constructed projects

#### PHARMA CARE



- National highway 4, Sihanoukville, Cambodia
- Pharmaceutical industry
- Solar energy + Li-ion batteries
- 500 kWp + 1080 kWh
- February 2018

## PAPUA NEW GUINEA

### Under construction

#### RD TUNA CORPORATION (RD GROUP)

Coming soon

- Madang, PNG
- Tuna canning
- Micro steam turbine
- 275 kWp
- 2018
- <http://www.rdgroupph.com>

## PHILIPPINES

### Constructed projects

#### CW HOME DEPOT

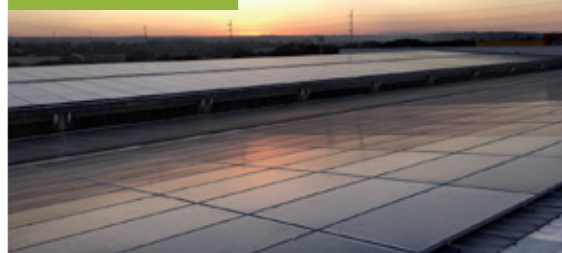

- Santa Rosa, Laguna, Philippines
- Hardware store
- Solar energy
- 1883 kWp
- 2016
- <http://cwhomedepot.com>

#### STEEL ASIA



- Davao, Philippines
- Steel rebar manufacturing
- Organic rankine cycle
- 125 kWp
- 2018
- <http://www.steelasia.com>

#### CEBU BELMONT



- Cebu, Philippines
- Hardware store
- Solar Energy
- 99.32 kWp
- 2017
- <https://www.belmontdepot.com>

#### ANVAYA COVE



- Bataan, Philippines
- Golf club
- Solar energy
- 40 kWp
- 2017
- <http://www.anvayacove.com>

#### SHOPWISE



- San Pedro, Laguna, Philippines
- Supermarket
- Solar energy
- 1100 kWp
- 2018
- <https://www.shopwise.com.ph>

#### ARC REFRESHMENTS (RC COLA)



- Cabuyao, Laguna, Philippines
- Food and beverage manufacturing
- Solar energy
- 1000 kWp
- 2017
- <http://www.arc.com.ph>

#### COAST PACIFIC



- Cebu, Philippines
- Furniture manufacturing
- Solar energy
- 100 kWp
- 2018
- <http://coast-pacific.com>

## Under construction

### CENTURY ICE PLANT

Coming soon

- Cebu, Philippines
- Block ice manufacturing
- cooling
- 104 kWc
- 2018

### PHILBEST CANNING CORPORATION (RD GROUP)

Coming soon

- General Santos, Philippines
- Tuna canning
- Micro steam turbine
- 275 kWc
- 2018
- <http://www.philbest.com.ph>

### ISLAND CENTRAL MACTAN

Coming soon

- Cebu, Philippines
- Shopping mall
- Solar power
- 400 kWp
- 2018
- <http://www.islandcentral.ph>

### LB SUPERMARKET

Coming soon

- Zamboanga, Philippines
- Supermarket
- Solar power
- 170 kWp
- 2018

### UNIVERSAL HARVESTER (UHI)

Coming soon

- Bukidnon, Philippines
- Dairy production
- Solar power
- 300 kWp
- 2018
- <http://universalharvester.com>

### GTI

Coming soon

- Cebu, Philippines
- Plastics production
- Solar power
- 400 kWp
- 2018

## AFRICA

### SOUTH AFRICA

#### Under development

### LEEUDORINGSTAD

Coming soon

- Leeudoringstad, South Africa
- Solar energy
- 5 MWp
- 2018

### WILDEBEESTKUIL

Coming soon

- Leeudoringstad, South Africa
- Solar energy
- 5 MWp
- 2018

For more references, please visit our website: <http://upgrade-energy.com/en/references/>



# UPGRADE ENERGY

TOGETHER WE EMPOWER  
YOUR ENERGY

UPGRADE ENERGY DEVELOPS ENERGY PROJECTS FROM START TO FINISH.  
CONTACT ONE OF OUR OFFICES FOR AN ENERGY CHECK-UP!

#### HEAD OFFICE BELGIUM

Deinsesteenweg 114  
9031 Drongen  
☎ +32 9 375 69 37  
✉ sales@upgrade-energy.com  
✉ info@upgrade-energy.com  
**RAF VERMEIRE - CEO**  
✉ raf@upgrade-energy.com  
**JENS CORNELIS - CFO**  
✉ jens@upgrade-energy.com  
**LISA MOERMAN - SALES**  
✉ lisa@upgrade-energy.com

#### UPGRADE ENERGY TURKEY

Bati Ataşehir Deluxia Palace  
Sitesi kat:13 daire:379  
Ataşehir-istanbul  
✉ turkey@upgrade-energy.com  
**MURAT CICEKCI**  
**MANAGER TURKEY**  
✉ murat@upgrade-energy.com

#### UPGRADE ENERGY POLAND

Olszewskiego 6  
25-663 Kielce  
☎ +48 41 278 72 78  
✉ poland@upgrade-energy.com  
**PIET DE ROOVER**  
**HEAD OF ENGINEERING**  
✉ piet@upgrade-energy.com

#### UPGRADE ENERGY CROATIA

Velimira Škorpika 17b  
HR-22000 Šibenik  
☎ +385 (0)22 331 787  
✉ croatia@upgrade-energy.com  
**MARTIN KRSTIC**  
**MANAGER CROATIA**  
✉ martin@upgrade-energy.com

#### UPGRADE ENERGY B&H

Biskupa Čule b.b.  
88000 Mostar  
☎ +387 63 170 685

#### DAVOR JOVIĆ

**MANAGER B&H**

✉ davor@upgrade-energy.com

#### UPGRADE ENERGY HONG KONG

Room 2004, 20F, Centre Point,  
81-185 Gloucester Road,  
Wan Chai, Hong Kong  
☎ +852 97 43 25 33  
✉ hongkong@upgrade-energy.com  
**PIETERJAN VANBUGGENHOUT**  
**INVESTMENT MANAGER ASIA**  
✉ pieterjan@upgrade-energy.com

#### UPGRADE ENERGY PHILIPPINES

318-B LRI Business Plaza,  
210 N. Garcia St.  
Bel-Air, Makati City, Philippines, 1209  
☎ +63 (0)2 403 6389  
✉ philippines@upgrade-energy.com  
**RUTH YU-OWEN**  
**MANAGER PHILIPPINES**

#### UPGRADE ENERGY SOUTH-AFRICA

8 Farm Road  
7200 Fisherhaven  
South-Africa  
☎ +27 79 1586706  
**PIETER-JAN STAELENS**  
**MANAGER SOUTH-AFRICA**  
✉ pieterjan.staelens@upgrade-energy.com

#### UPGRADE ENERGY CAMBODIA

PPIU Building, 11th floor, Street 169,  
Sangkat Veal Vong, Khan 7 Makara,  
Phnom Penh  
☎ +855 12336657  
**PHANNY SRAS**  
**MANAGER CAMBODIA**  
✉ phanny@upgrade-energy.com